

ISSN 1726-5749

# SENSORS & TRANSDUCERS

vol. 82  
**8**/07



## Sensors and Transducers Applications

International Frequency Sensor Association Publishing





## Sensor Signal Conditioning

David CHEEKE

Microbridge Technologies Inc.

*Received: 29 June 2007 /Accepted: 20 August 2007 /Published: 27 August 2007*

---

**Abstract:** The general problem of sensor signal conditioning is approached from the point of view of separating the intrinsic sensor properties from those associated with inserting the sensor into a conditioning circuit. This gives rise to a check list of attributes which would be useful to localize problems which may arise in using sensing devices.

A second part of the presentation provides a survey of traditional sensor conditioning techniques, going from simple analog op amp solutions to sophisticated digital technology using DSP and look up tables of correction coefficients.

A final section covers the use of a promising new passive analog technology to adjust resistance values using Rejutors. It is demonstrated that the Rejutor performance compares favorably to its digital counterpart, the digital potentiometer. It is concluded that the Rejutor could provide a simple and elegant solution to many sensor signal conditioning problems. *Copyright © 2007 IFSA.*

**Keywords:** Sensor signal conditioning, Rejutor, Analog sensor signal processor, DSP

---

### 1. Introduction

As divisional manager, you have just decided to upgrade your set of gas sensors installed on the factory floor. Some of the gases involved are very toxic so you want to be sure that you choose the best sensors and get them installed correctly so that they will work reliably for many years. What are the parameters that you control in this process? What are those that you don't? How can you improve the reliability of your sensors? What are the things to look out for in the choices to be made between different types of sensors and conditioning chips? These are some of the questions that this article addresses on a generic level, with the objective of clearly establishing the separate areas of

responsibility of the sensor manufacturer and of the designer of the associated conditioning circuitry. An approach using a new analog technology that has exciting potential will also be presented.

A summary of the various sensor attributes is given in Table 1. Many of these are associated primarily with the sensor, some primarily with the conditioning circuit and others which involve both sensor and circuit. This distinction is not meant to be interpreted categorically, but its purpose is rather to show at which level a problem is normally found. For example, irreversibility or hysteresis is strictly a sensor problem, and no amount of external circuitry can correct for it. Offset can be classified as fundamentally a circuit problem and appropriate circuit parameters need to be chosen to compensate offset for a given sensor. Finally, spurious variations with temperature can happen in both sensor and circuit, so both sources must be considered when applying corrective action.

**Table 1.** Table of sensor parameters, distinguishing sensor, sensor-circuit and circuit concerns.

<b>Mainly Sensor</b>	Calibration
	Saturation
	Sensitivity
	Minimum detectable signal
	Selectivity
	Reversibility
	Reproducibility
	Aging
	Response time
<b>Sensor and Electronics</b>	Drift
	Noise
	Linearity
	Dynamic response
<b>Mainly Electronics</b>	Offset
	Span
	Stray resistance
	Thermoelectric effects
	Device temperature

The various parameters dependent mainly on the sensor are summarized below:

- Calibration. This is basically a manufacturing issue, and the official calibration data of the sensor, with accuracy, temperature range etc, are normally supplied by the manufacturer.
- Saturation. As with all electronic devices, sensors have a linear regime (generally small signal) and at some point for large enough stimuli the output will start to saturate. This is shown generically in Fig. 1 (a) for the intrinsic response of an ideal sensor. The user must be incorporate the linear region into the functional range of the sensor and avoid using it in the saturation regime.
- Sensitivity. This is given by the slope of Fig.1 (a), i.e., the marginal increase in output for a marginal stimulus increase. Not to be confused with the minimum detectable signal.
- Minimum detectable signal. The smallest signal that can be accurately measured. This is particularly important for gas sensors that are used to measure trace amounts of material and magnetic field sensors.
- Selectivity (Absence of cross effects). Cross effects can be a real problem for the manufacturers (and users!) of certain types of sensors. For example, polymer films are commonly used for gas sensing, but they are notoriously sensitive to humidity, which we call a cross effect. Obviously it is

very important to be certain that you are indeed measuring what you want to sense and not some extraneous effect.

- Irreversibility (Hysteresis). This is again a manufacturing issue or a property of the materials used in the sensor, and unless it is quantifiable cannot be compensated by circuitry. Many sensing mechanisms, such as those based on magnetic materials are intrinsically susceptible to this effect.
- Reproducibility. Two nominally identical sensors from the same batch should give the same response to a given stimulus. If not, sensors might have to be calibrated individually.
- Aging. This can be described as a slow drift of sensor properties with time over the long term. There can be many causes, usually mostly related to slow degradation of the sensing material itself. If the change is constant with time it could in principle be compensated.
- Response time. Not usually a problem, but it can be very long (minutes, hours) for some adsorption based gas sensors, especially after continual use and hence when the sensor is near the saturation regime.

There is a related list of properties where both the sensor and the conditioning electronics are typically equally important:

- Drift. This term is often used for the specific case of cross effects due to temperature variations, although some use the term to describe any variation with time.
- Noise. Noise may originate from the sensor (e.g., Johnson noise for resistive sensors) or from the conditioning circuit.
- Linearity. Departures from linearity, including nonlinear thermal effects may come from the sensor and the associated circuitry. This can often be corrected by the use of polynomial functions, as would be the case for the total system response shown in Fig. 1(b). The task of the signal conditioning is to linearise the effective output signal from the system.
- Dynamic response. This may be intrinsic to the sensor; for example, ultrasonic sensors operate at high frequencies and have a characteristic frequency response. This may be strongly modified by the circuit, usually due to stray capacitance or stray inductance.

Finally, there are several important system parameters which are usually determined by the circuitry alone:

- Offset. For the case of a resistive sensor in a Wheatstone bridge, an offset voltage will occur if the bridge is not balanced in the absence of a stimulus. The offset must be corrected either by trimming bridge resistors or using compensation at later stages.
- Span. This can be defined as the full scale output minus the offset. If the gain is varied then several ranges in the output signal are possible.
- Stray lead and contact resistances, which must be compensated.
- Stray thermoelectric voltages which will occur if temperature gradients are present.
- Device temperature. Several systems use onboard EEPROMS and lookup tables to correct for temperature variations. Great care must then be taken to reduce the thermal contact resistance between the sensor and the thermal sink of the circuitry. If this isn't done there will be potentially large errors in the estimated sensor temperature and the whole exercise becomes pointless.

In the next two sections it will be shown how this class of circuit issues has been addressed by traditional sensor conditioning and then how the problem could be approached using a new, analog, Rejistor-based technology.

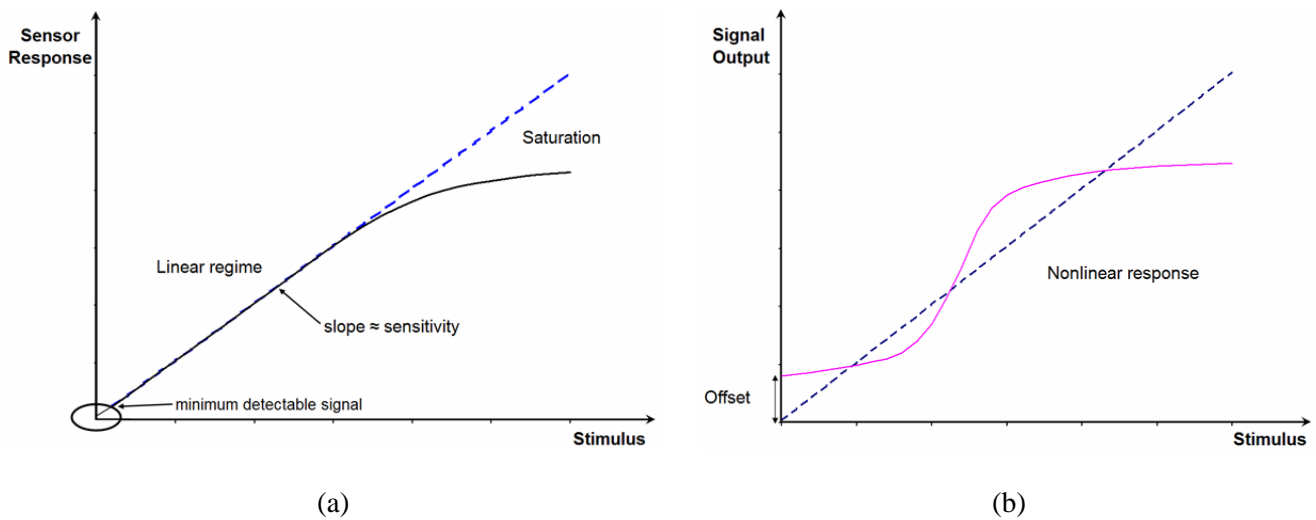

**Fig. 1.** Sensor stimulus response curves

- (a) Idealized sensor response;  
 (b) Possible output signal for a real world, non-conditioned sensor and amplifier circuit.

## 2. Traditional Sensor Conditioning

There is a hierarchy of possible approaches to sensor conditioning, which to some extent follows chronologically, in that the first systems were based on simple analog circuits, followed by a trend towards increasing use of digital techniques. The resistance-based sensor in a Wheatstone bridge measurement configuration will be considered for discussion purposes.

Historically analog conditioning was based on a simple readout of the output voltage of the bridge. Various ingenious techniques were devised to compensate for spurious thermal effects. For the special case of resistive temperature sensors, the  $R(T)$  characteristic could be linearized by the suitable choice of two resistances in series with different static temperature coefficients, such as Platinum and Nickel. For other than temperature sensors, thermal drift effects in the bridge could be compensated in a similar fashion by choosing the bridge resistive elements to give constant ratios as a function of temperature, leading to an approximately temperature independent output. Another trick that is especially useful for strain gauges is to use two or four active elements in the bridge. The latter case provides very good temperature compensation and an output that is four times larger than for a single element.

While the basic bridge circuit is simple enough it presents several challenges. The output is small (microvolts to millivolts) riding on a high common mode DC level and has associated temperature dependent noise and offset. All of these aspects must be addressed by the conditioner. A fairly standard analog sensor signal processor (ASSP) approach, which can be designated as first generation, uses an instrumentation amplifier (in amp). The latter amplifies the bridge's difference voltage and also gives good rejection of common mode noise. In this simple example, offset errors would be trimmed out manually. This first generation approach has the big advantage of simplicity, but it has poor performance compared to more recent solutions, particularly regarding compensation for nonlinearities and temperature. Moreover, manual adjustment by tweaking pots is time consuming and hence expensive.

A significant improvement on the basic in - amp can be obtained by use of a programmable amplifier, such as the Analog Devices AD 8555. This is a zero drift bridge sensor amplifier with programmable gain and offset. The latter feature is provided by Digitrim technology, whereby appropriate resistance

values are determined experimentally for the circuit at hand and then set permanently by blowing on board Polysilicon fuses. This chip provides a clear path from the bridge to an ADC and subsequent further signal processing. Other useful features for practical applications are a fault detector for short, open or floating inputs and the possibility of adding a low pass filter.

Other recent conditioners exploit the advantages of digital technology on board the chip and adopt a hybrid approach in an attempt to get the best of both worlds. The first members of this group are still ASSP devices, in that all of the actual signal processing is done in the analog domain. The improvement is that compensation data for linearization, temperature and offset compensation etc are stored in an EEPROM, as are digitized data from an onboard temperature sensor converted by an ADC. A simplified block diagram of a generic device is shown in Fig 2. The stored data is accessed by an on board DAC, and the offset and gain data are supplied directly to the analog amplifier. Linearization is carried out by using the stored linearization data to scale the bridge supply voltage. This purely analog conditioning is simple and eliminates the brute force curve fitting of the all digital processor to be described below. However there is the cost and bother associated with inputting the stored data. Also, the DAC, which is the heart of the system, must be high resolution for a high performance device, and this can be expensive. Examples of this type of conditioner are the Texas Instruments PGA 309, the Maxim MAX 1450 (basic), MAX1458 (mid range) and MAX 1457 (top end).

An alternative approach is to use analog technology for the front end and DSP for compensation and error correction functionality. The sensor IC conditioning chip is built by mixed signal CMOS technology. A simplified generic block diagram is shown in Fig. 3. The input from a sensor bridge is applied to a PGA with four gain settings and coarse input control. The data from a temperature sensor which has a supply voltage ratiometric with the sensor bridge is analog multiplexed, together with the sensor data, the whole then converted by a 16 bit ADC for digital processing. Calculation and compensation coefficients are stored in an EEPROM. The DSP uses this data and the digitized temperature data to calculate compensation corrections, which are then passed to an analog or 12 bit digital output. The use of high precision DSP, DAC and ADC allows accurate treatment of first and second order temperature effects for gain, offset and sensor response. Typical performance numbers for a chip of this type, the MAX 1460, are better than 0.5% overall accuracy and span and offset errors less than 0.05%. The ZMD 31015 is another example of a conditioner employing DSP.

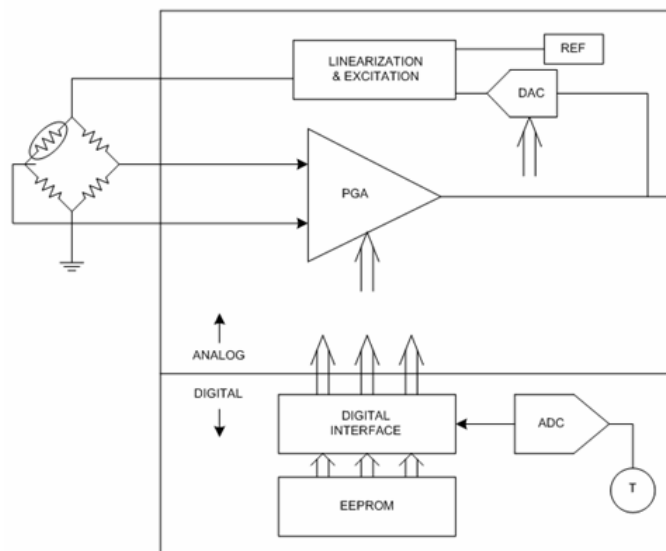

**Fig. 2.** Block diagram of ASSP conditioner.

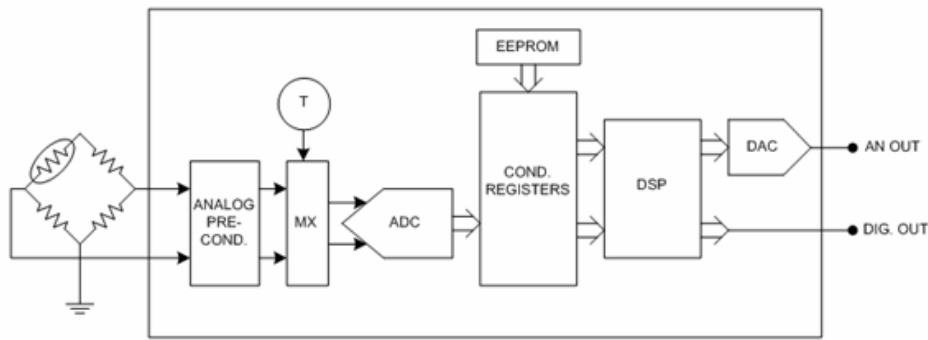

Fig. 3. Block diagram of DSP conditioner.

### Passive Analog Compensation Using Rejutors

Recently a different approach has been developed for analog adjustment and sensor conditioning using a new passive resistor technology. Microbridge's Rejutor is a passive, VLSI and MEMS compatible, adjustable micro-resistor. It is based on standard CMOS technology, whereby a Polysilicon resistance and its associated heating resistor are situated on a suspended microstructure created by bulk micromachining. The resulting high thermal isolation permits the microstructure to quickly rise to temperatures of the order of 500-800C with a few milliwatts of local heating. Polysilicon is a thermally mutable material, so that the electrical resistance changes with each heating cycle. The use of an adaptive algorithm to control the heating sequence allows the steady state resistance to be varied over a wide range, typically as much as 30% down from the initial value. A full account of the Rejutor technology, together with a number of applications, has been given elsewhere (4).

There are many characteristics of the Rejutor that are of interest in the present context. Firstly, it is passive and non-volatile, which makes it very flexible in this application. The operation is reversible and can be repeated many times, so this is not a one-off process like burning fuses. The footprint of the device is small (typically a few hundred microns square) and the process is CMOS compatible, so that the technology could easily be integrated into an IC. Most importantly, the resistance of the Rejutor can be varied after packaging, so that adjustment by the user in field conditions is not only feasible but desirable for many applications. Finally, it has been found that over a limited range the temperature dependant coefficient of resistance or TCR of the Rejutor can be varied independently from the absolute value of the resistance (Microbridge's eTCR product line). This makes the device a tailor made candidate for sensor conditioning, where both functions are required.

Intuitively, the most obvious application of Rejutors to sensor conditioning is to use them in the arms of the Wheatstone bridge, both as reference and ratio resistors, as shown in Fig. 4. The bridge can be balanced at ambient temperature, giving a coarse offset control. Careful choice of eTCR matching can be used to compensate temperature drift.

Rejutors can be used equally effectively at the gain stages. They have a natural application area in the gain and offset of op amps, as shown in Fig.5. Relative to input voltages, offsets of a few microvolts and gain control better than 0.1% are attainable. The eTCR of these Rejutors can be controlled to compensate the drift of the op amp and associated circuitry. If one is looking for high precision and stability then even small temperature changes can be deleterious. In this context, advantage can be taken of the use of TCR matched pairs of Rejutors, so that their relative TCR (RTCR) effect is as small as possible.

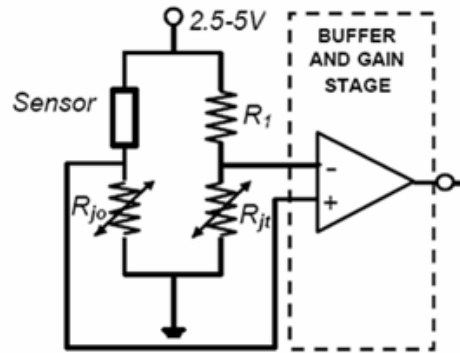

**Fig. 4.** Rejutors in Wheatstone bridge circuit. ( Ref.4).

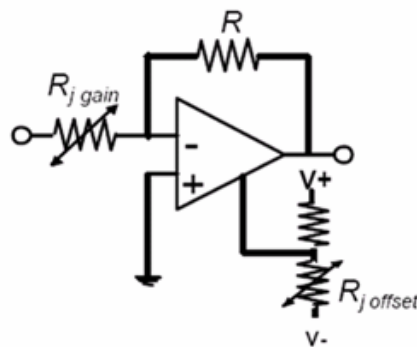

**Fig. 5.** Rejutors for op amp adjustment. (Ref.4).

Rejutors can be used to great effect in differential in - amps, which we have seen are very useful for ASSP. An example is shown in Fig. 6, which is explained in detail in reference 4. All of the resistors in this circuit could be replaced by Rejutors, which would provide high CMRR and sensitive gain and offset control. Recalling the various functions required of the sensor circuitry, it is clear from the above that conditioning problems relating to gain, offset and thermal effects can be effectively addressed by the use of Rejutors. The gain and offset functions would normally be carried out using a trim pot, or more recently by devices such as a digital potentiometer. A comparison of some of the principal characteristics of a Rejutor and a recent model digital potentiometer is shown in Table 2. Clearly the Rejutor compares favorably as regards resolution, temperature range and frequency response, whereas the digital potentiometer has a lower TCR. It is also possible to have much larger resistance excursions with the latter. However, the big advantage of using the Rejutor is that thermal effects can be compensated independently of the resistance values. In many cases this will be sufficient to solve the whole sensor conditioning problem, resulting in significant advantages in cost saving and simplicity.

Drift with time and aging could be dealt with in principle by periodic re-adjustment of the Rejutors or re-calibration, taking advantage of the field adjustment capability. If the drift was very regular with time this compensation could even be programmed by additional circuitry in the system to take place continuously or periodically. Linearization with respect to temperature is in principle addressable by use of an appropriate series-parallel combination of Rejutors in the spirit of classical passive analog signal processing; of course here the approach is much more powerful, thanks to the unique feature of independently controllable R and TCR. Indeed, with the possibilities of integration and programmability, the future looks very bright for the widespread application of Rejutors in sensor conditioning.

**Table 2.** Performance comparison of Low-TCR Rejutor and MAX 5128 digital potentiometer.

Parameter	Low TCR Rejutor	Digital Potentiometer MAX 5128
Package Size (mm)	3 x 3 Typical	2 X 2
Resolution	< 0.1%	< 1%
Temperature range	-40C to + 125C	-40C to +85C
Ratiometric TCR (ppm/C)	50 ppm/K	5
TCR (ppm/C)	100 ppm/K	50
Standby supply current	Nil (passive)	1.5 micro amps
Maximum frequency	> 2 GHz	400kHz *
Interface	Rejust-It software and 2 trim pins	2 wire digital (up/down) calibration and power
Cost ( \$US,1000 up)	0.53 **	0.68

\* Wiper bandwidth

\*\* Rejutor supplied in a dual package costing \$1.06

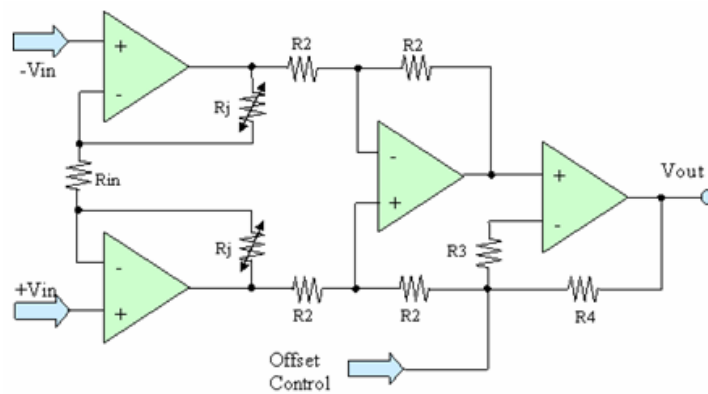

**Fig. 6.** Rejutors in instrumentation amplifiers ( Ref.4).

## References

- [1]. R. Pallas-Areny and J. G. Webster, Sensors and Signal Conditioning, *John Wiley & Sons*, New York, 1991.
- [2]. TI Product Note for PGA309, #SBOS92B, Revised January 2005.
- [3]. Maxim Application Note 743 (see also the January 2001 issue of *Sensor Magazine*).
- [4]. [Http://www.mbridgetech.com](http://www.mbridgetech.com) - for technical articles on the Rejutor technology. The articles "Rejutor electrically adjustable resistor technology" and " Rejutor based amplifier compensation" are directly relevant to the present discussion.