

The MBW-303 is a passive **Rejistor** network for offset calibration with offset temperature compensation. The **Rejistor** network, shown in Figure 1, is suitable for compensating Wheatstone Bridge sensors with a typical bridge resistance in a range from 3kΩ to 6kΩ. It is also suitable for compensating other analog circuits. The available adjustment range and precision will vary depending on the sensor resistance and TCR, or properties of the surrounding circuitry.

The MBW-303 performs passive compensation for offset and temperature coefficient of offset (TC_Offset). This completely passive solution requires no additional power to maintain its adjustment during storage or operation.

The MBW-303 from Microbridge is the ideal passive signal calibration to zero a bridge or provide a temperature compensated zero-reference. This feature is useful for maximizing the input range of ADC or amplifiers connected in Wheatstone Bridge sensors applications.

FEATURES

- Suitable for Wheatstone Bridge sensors that require offset correction with or without temperature compensation
- True, passive calibration and compensation solution
- Calibrates offset
- Compensates Temperature Coefficient of Offset
- Fully analog, completely passive
- Operating Temperature Range -50 °C to +150 °C
- Requires no power to maintain adjustment
- No external temperature sensor required
- In-circuit adjustable at wafer, component, board or system level
- RoHS and Pb-free and green compliant
- Available in 16-pin QFN package

BENEFITS

- Completely passive solution
- Precision electrical in-circuit adjustment for ohmic and temperature correction
- Single chip solution for offset compensation of a Wheatstone Bridge at the source of errors
- Adjustment and verification can be performed in a single temperature cycle
- Dynamic adjustment provides cost and labor savings
- Flexibility reduces rework
- Re-adjustable
- Low noise – comparable to thin-film resistors
- Eliminates laser trimming
- Small foot print for high density applications
- Non-Volatile, set and forget adjustment. Requires no power during operation or storage
- Automated temperature compensation in the analog domain for circuits with temperature-induced error
- Null out the cumulative temperature-sensitivities of the sensor

APPLICATIONS

- Suitable for all Wheatstone Bridge implementations
 - Pressure
 - Magnetic
 - Acceleration
- Suitable for use in Voltage Excitation Applications
- Analog circuit compensation

FUNCTIONAL SCHEMATIC DIAGRAM

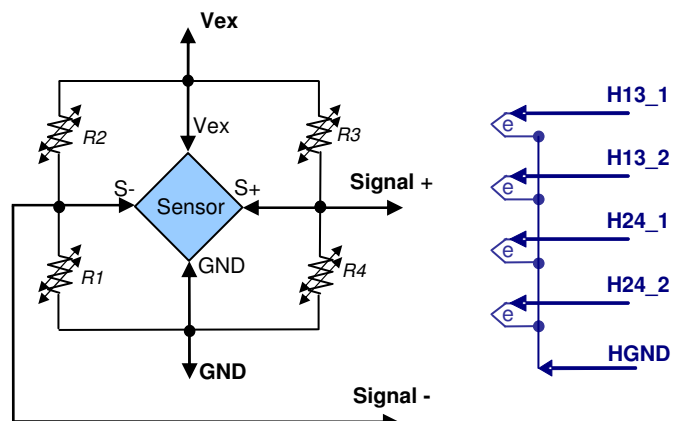

Figure 1: Schematic

Information furnished by Microbridge Technologies is believed to be accurate and reliable. However, no responsibility is assumed by Microbridge Technologies for its use, nor for any infringements of patents or other rights of third parties that may result from its use. Specifications subject to change without notice. No license is granted by implication or otherwise under any patent or patent rights of Microbridge Technologies. Trademarks and registered trademarks are the property of their respective companies.

Table 1: RATINGS – Rejustors 0°C < T_A < +70°C; unless otherwise noted

Item	Conditions	Typical Specifications
Rated Power (per <i>Rejustor</i>)		1.0mW
Operating Temperature	As specified in this datasheet	0°C to +70°C
	As specified in Application Note “ <i>Rejustor</i> Operating Guidelines for -40 to +125°C Operation”	-40 to +125°C
	Beyond -40 to +125°C	Contact Microbridge
Isolation Voltage (between any pins)	Subject to power limits	25V
Relative self-heating change in resistance	When both <i>Rejustors</i> carry the same current	<0.4%
Nominal Pair Ratio Matching	Unadjusted	±3% (e.g. 1.03 : 1.00)
Nominal Resistance	Per <i>Rejustor</i>	30,000Ω, ±10%
Adjustment Range	<i>Rejustor</i> network only	Refer to Figure 2
	<i>Rejustor</i> network with Sensor having resistance = 5kΩ, TCR = +2400ppm/K as an example.	Refer to Figure 3
Offset adjustment precision	<i>Rejustor</i> network only	±0.5mV/V ¹ within adjustment range with adjustment feedback measurement directly related to bridge output voltage
	<i>Rejustor</i> network with Sensor having resistance = 5kΩ, TCR = +2400ppm/K as an example.	±0.1mV/V ¹ within adjustment range with adjustment feedback measurement directly related to bridge output voltage at zero sensor stimulus
TC-Offset adjustment precision	<i>Rejustor</i> network only	±5μV/VK within adjustment range assuming two TC measurements (coarse and fine) and adjustment feedback measurement directly related to bridge output voltage
	<i>Rejustor</i> network with Sensor having resistance = 5kΩ, TCR = +2400ppm/K as an example.	±0.5μV/VK within adjustment range assuming two TC measurements (coarse and fine) and adjustment feedback measurement directly related to bridge output voltage at zero sensor stimulus
Adjustment Time		1 to 5 sec ²

Table 2: RELIABILITY DATA

Characteristics	Limit	Test Method or Conditions
Thermal Shock/ Cycling	±1mV/V ³	JESD22-A104, -65°C to 125°C, 1000 cycles at 2 cycles/hour
High Temperature Exposure (long-term stability)	±1mV/V ³	JESD22-A103 150°C, 1000hrs
Humidity and Moisture Resistance	±1mV/V ³	JESD22-A101, 85% RH, 85°C, 1000hrs
Operational Life Test	±1mV/V ³	JESD22-A108, 125°C, 1000 hrs., static operation at rated power, by analysis
Shock	± 0.3mV/V	500G, 1ms duration, X,Y,Z axes each 5 shocks
Vibration, High Frequency	± 0.3mV/V	Max acceleration 20G, 20~2000~20Hz, 8 min, X,Y,Z each 4 sweeps

¹ Adjustment precision is limited by temperature control, accuracy of measurement and adjustment equipment and may increase adjustment time.

² Using Microbridge’s scalable production-calibration hardware (based on the NI-DAQ platform from National Instruments) and Rejust-it software, multiple units can be calibrated simultaneously during roughly the same amount of time.

³ Resistance drifts in a positive direction. Best stability is achieved at adjustments at least 10% down from the as-manufactured resistance.

Table 3: MANUFACTURABILITY DATA

Characteristics	Test Method or Conditions
ESD Discharge	JESD22-A114, human body model weakest pin pair, all lead combinations. Class 1A
Solderability/ Preconditioning	J-STD-020C, MSL1, 260 deg C convection reflow for QFN-16 packages

PACKAGING OPTIONS

Table 4: NOMINAL PACKAGE DIMENSIONS

Type	Lead Count	Body Width	Body Length	Lead Pitch	Lead Width	Lead Length	Body Thickness	JEDEC/ EIAJ	Available
QFN	16	3.0mm m	3.0mm	0.5mm	0.25mm	0.4mm	0.85mm	MO-220	Samples

ADJUSTMENT RANGES

The available zones of adjustment are shown in the 2-dimensional plots below (figure 2 and Figure 3). The parallelogram-shaped regions show the available adjustment range for the combination of offset and TC_offset values.

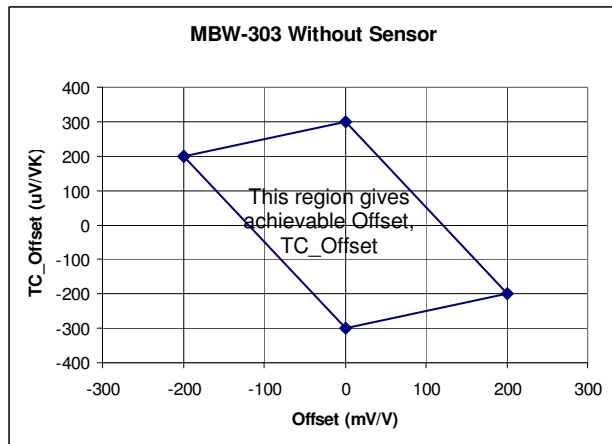

Figure 2: MBW-303 Without Sensor

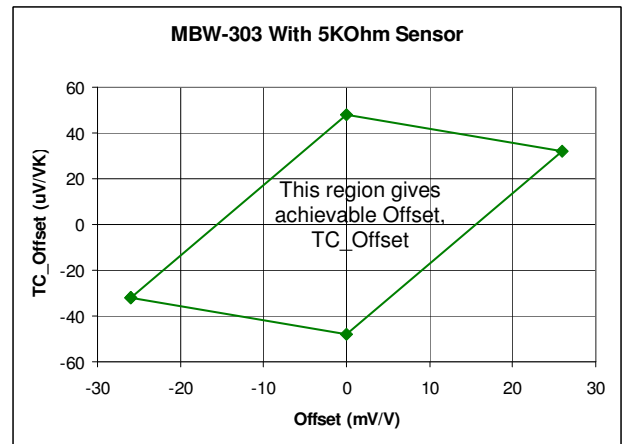

Figure 3: MBW-303 With 5kΩ, +2400ppm/K Sensor

GENERAL OVERVIEW

The MBW-303 is a passive compensation device for correcting offset and offset temperature drift in Wheatstone Bridge sensors. The **Rejistor** elements are connected in parallel with each sensing element. Each **Rejistor** has a nominal resistance of approximately 30KΩ to avoid loading and reducing sensitivity of the sensing element. The resistance and TCR of each **Rejistor** are independently adjusted to compensate the overall sensor offset and counteract offset-related temperature drift in the sensor.

Rejistors are passive resistors with the ability to have their resistance adjusted using auxiliary pins (refer to adjustment procedure, below, for more information). **Rejistors** in the MBW-303 allow precision adjustment for offset calibration. **Rejistors** can be adjusted in an analog manner to very high precision – eliminating quantization errors while providing the lowest noise of any adjustable resistor technology.

The resistance of the **Rejistor** is adjusted using **Rejistor** Calibration tools to provide offset and TC_Offset compensation to match the characteristics of the sensor on a unit-by-unit basis. As an electrically adjustable device, there are no moving parts and no mechanical access is required to perform the adjustment. This means that the assembled sensor can be adjusted after potting and other encapsulation-type processes, yielding a high precision final product.

Once adjusted, **Rejistors** maintain their resistance and TCR indefinitely with high stability and precision. **Rejistors** can be re-adjusted any time by re-connecting the sensor and **Rejistor** network to the calibration tool. In addition, resistance temperature coefficients are set allowing true passive temperature conditioning and eliminating the requirement to monitor temperature. Essentially the material properties of the **Rejistor** are changed to compensate deviations in the material properties of the sensor.

Adjustment range and precision is provided for the case of the MBW-303 as a stand alone unit. The case of the MBW-303 with a 5KΩ, +2400ppm sensor is also provided as a representative example of the adjustment ranges and precision achievable with a sensor present. Achievable TC-Offset adjustment precision will depend on (and be affected by) measurement precision and on the knowledge (by the calibration software) of the resistance and TCR of the sensor bridge. As can be seen in Figures 2 and 3, the addition of the sensor decreases the adjustment range. However, as indicated in Table 1, the adjustment precision increases. When the MBW-303 is used to compensate bridge networks with high resistance, the compensation range is greater than it is for sensors with low resistance. The MBW-303 can also be used as a stand-alone device to provide an adjustable, temperature-compensated reference when used on the input of a differential amplifier (for example).

Rejostors have stable resistance and temperature coefficients when operated from 0°C to +70°C. The MBW-303 can operate from -50°C to +150°C, with some increased drift. Refer to Microbridge application note *Operating Guidelines for -40 to +125C Operation* for more information.

TYPICAL APPLICATION

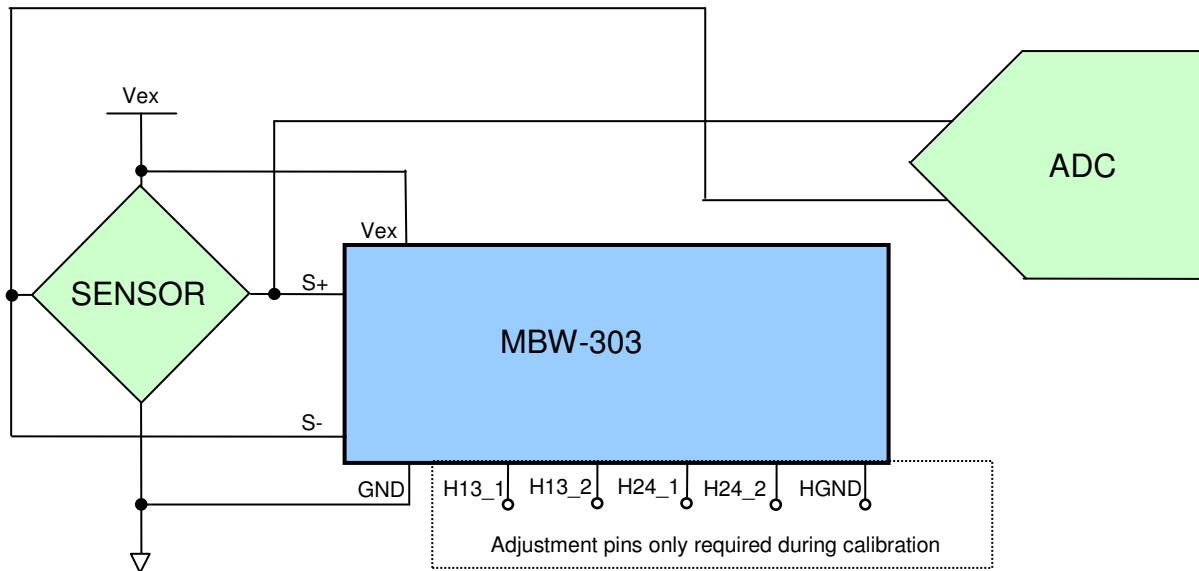

Figure 4: MBW-303 Compensated Sensor with Analog-to-Digital Converter Application Example

APPLICATION EXAMPLE

In some instances, Wheatstone Bridge sensors output a low signal-of-interest in the presence of a high offset signal. The input range of an amplifier or an ADC must be large enough to accept the signal along with offset. The MBW-303 can be used with Wheatstone Bridge sensors to remove the offset and temperature-induced offset drift so that the amplifier input range can be reduced to focus on the signal of interest. This improves performance of the amplification chain while reducing the signal-to-noise ratio (SNR) of the system.

The graphical representation in Figure 5 compares the usable range of the analog-to-digital converter for uncompensated and compensated sensors. The left side shows a sensor with a specified 5mV full-scale-output (FSO) and an offset in the range of 0 to 30mV. In this example the offset is shown at 10mV. Notice that the FSO is only 15% of the input range of the ADC. In other words, the active range of a 12-bit ADC is underutilized. The problem is further exacerbated when temperature-induced drift of offset is included.

The example on the right shows a sensor with offset correction using the MBW-303. Notice that the Offset has been corrected to zero, now the full-scale span of sensor is equal to the full-scale input span of the ADC. All the available bits of the ADC are dedicated to the signal of interest.

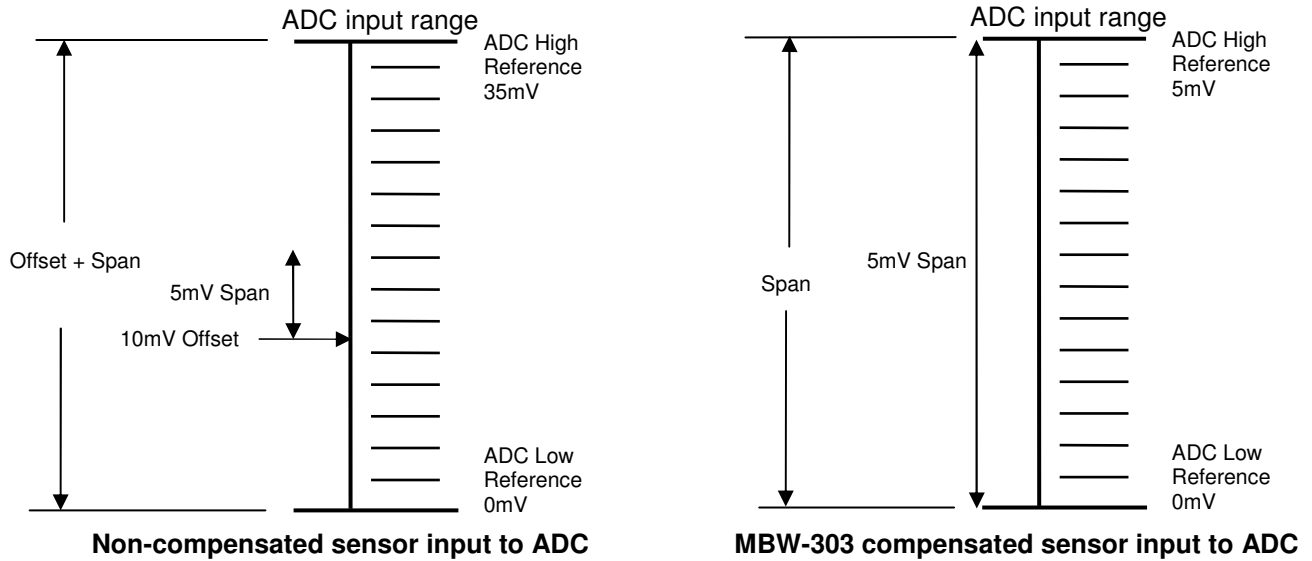

Figure 5: Example of Offset Compensation

ADJUSTMENT PROCEDURE

Precision adjustment of the resistance and TCR of each **Rejistor** during calibration is accomplished by means of a proprietary process which adjusts the resistive poly-silicon element in a closed-loop system under control of **Rejistor** Calibration tools and **Rejust-it** software. After adjustment, the set value of the calibrated **Rejistor** is stable from 0°C to +70°C.

The adjustment pins (H13_1, H13_2, H24_1, H24_2 and HGND) are only required during the short period during which the **Rejistors** are being adjusted. The resistance and TCR of each **Rejistor** are adjusted by applying a controlled current between the corresponding pin and HGND.

Rejistors are adjusted using **Rejistor** Calibration Tools, such as the MBK-408A – Low cost, high-precision **Rejistor** Calibration tool. **Rejistors** can also be adjusted with the MBK-600, high-volume, high-precision Calibration tool based on the National Instruments NI-DAQ chassis.

The nominal sensor resistance and TCR must be provided as input parameters to **Rejust-it**. During the calibration process, the **Rejistor** is connected to the **Rejistor** Calibration Tool, or equivalent hardware⁴. The Calibration tool provides the electrical connections to monitor the circuit output behavior and drive power into the Adjustment pins of the **Rejistor**. Power applied to the Adjustment pins controls the heating and cooling process which in-turn changes the resistance. Refer to figure 5 for a sample connection between the MBK-408A **Rejistor** Calibration tool and the **Rejistor**. Connection to the calibration tool is only required during adjustment.

Rejust-it software, provided with the **Rejistor** Calibration Tool as royalty-free LabVIEW-based executable, controls the adjustment process using the **Rejistor** Calibration Tool in a closed-loop feedback system. **Rejistors** are automatically adjusted to the target values, as specified in the graphical user interface. A sequence of electrical heating pulses, governed by Microbridge’s proprietary algorithms, is enough to fine-tune the material properties within approximately 5 second for most applications after the performance of the sensor has been measured.

The calibration process requires no-load data points at low and high temperatures. **Rejistors** are adjusted using the adjustment pins (refer to Table 5). These pins must be connected to the adjustment hardware to change the **Rejistors** to meet the requirements of the sensor. Recognizing that these pins are only required during calibration affects design of the calibration fixture. In normal operation these pins can be left open, or grounded with no impact. The calibration fixture can be designed to allow connection to the adjustment pins with pogo-pins, probes or similar temporary connections. Optionally, a header can be designed on the PCB to allow connection between the adjustment pins and the calibration hardware.

Once the **Rejistors** have been adjusted no further action is required. **Rejistors** retain their resistance and TCR values in their material properties and no further changes are required. No boot-up or warm period is required for the **Rejistors**.

⁴ Using Microbridge’s scalable MBK-600 production-calibration hardware (based on the NI-DAQ platform from National Instruments) and Rejust-it software, multiple units can be calibrated simultaneously during roughly the same amount of time for high-volume applications.

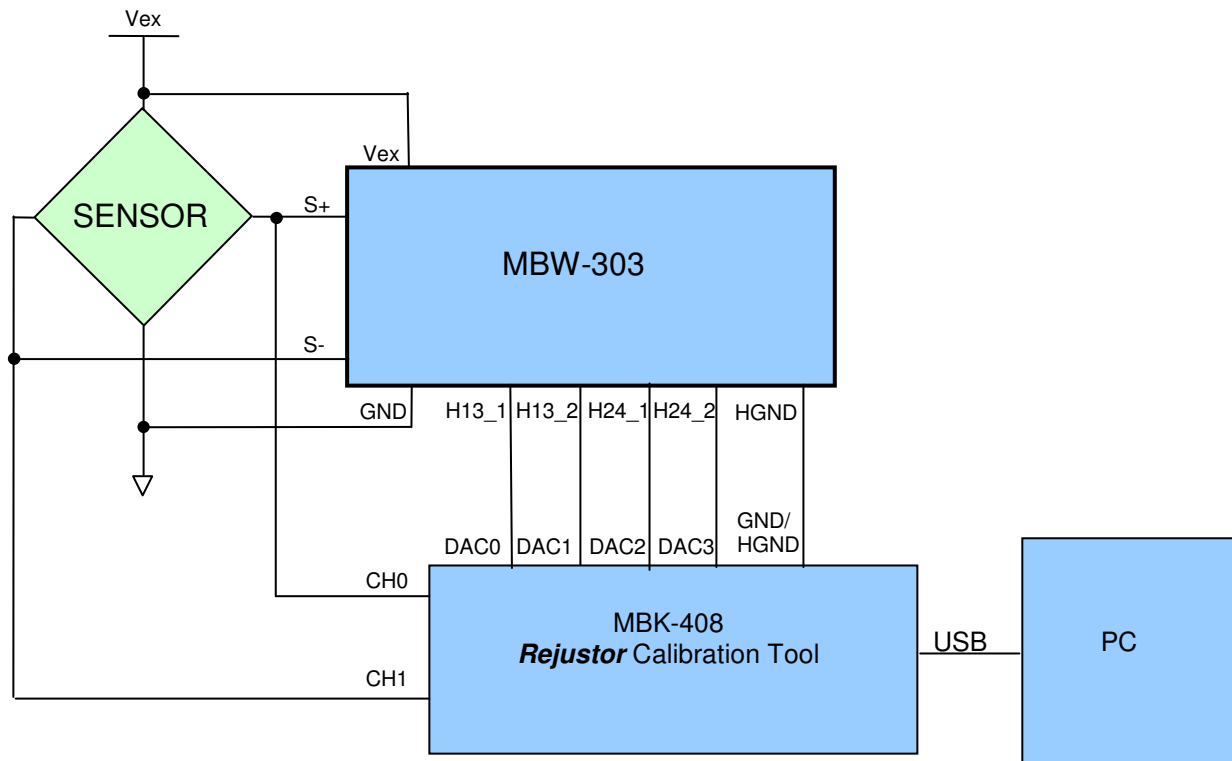

Figure 5: MBW-303 Adjustment Configuration with MBK-408, Low-cost *Rejistor* Calibration Tool

PIN FUNCTIONAL DESCRIPTION

Table 5: PIN FUNCTION DESCRIPTIONS

Signal	Pin Number	Description	Function
Vex	3	Excitation Voltage	Supply
GND	1	Analog ground	Analog ground
S+	4	Positive Input (from sensor)	Positive differential input from Bridge.
S-	2	Negative Input (from sensor)	Negative differential input from Bridge.
H13_1	10	Rejutors R1 and R3 TC and resistance adjustment pin #1	Adjusts offset and TC_Offset of Rejutors R1 and R3. Signal applied between H13_1 and HGND under Rejust-it control. Signal is only connected during adjustment
H13_2	12	Rejutors R1 and R3 TC and resistance adjustment pin #2	Adjusts offset and TC_Offset of Rejutors R1 and R3. Signal applied between H13_2 and HGND under Rejust-it control. Signal is only connected during adjustment
H24_1	9	Rejutors R2 and R4 TC and resistance adjustment pin #1	Adjusts offset and TC_Offset of Rejutors R2 and R4. Signal applied between H24_1 and HGND under Rejust-it control. Signal is only connected during adjustment
H24_2	11	Rejutors R2 and R4 TC and resistance adjustment pin #2	Adjusts offset and TC_Offset of Rejutors R2 and R4. Signal applied between H24_2 and HGND under Rejust-it control. Signal is only connected during adjustment
HGND	8	Adjustment Ground	Ground for Rejistor adjustment. Only required during Rejistor adjustment

PIN CONFIGURATION

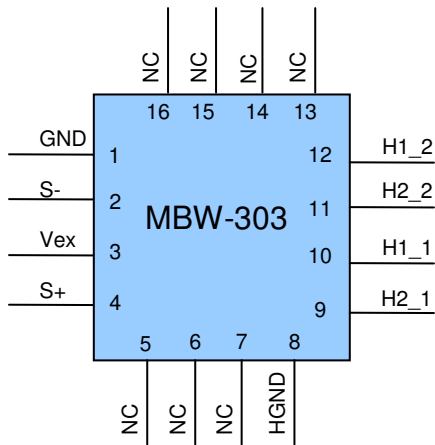
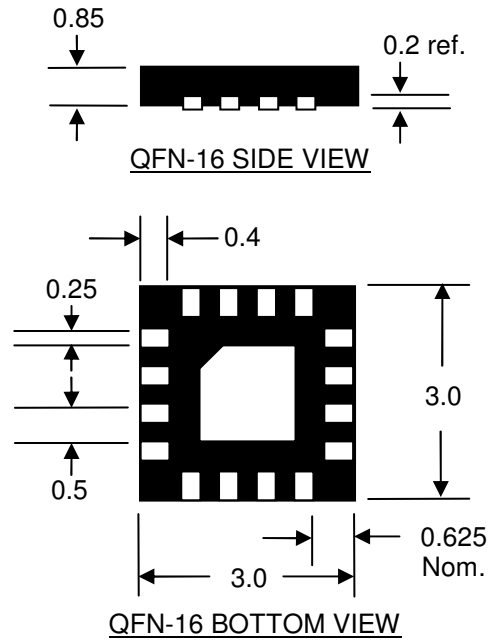

Figure 6: MBW-303 Pin Configuration



All dimensions in millimeters

Figure 7: Package Dimensions

TAPE CARRIER PACKAGING

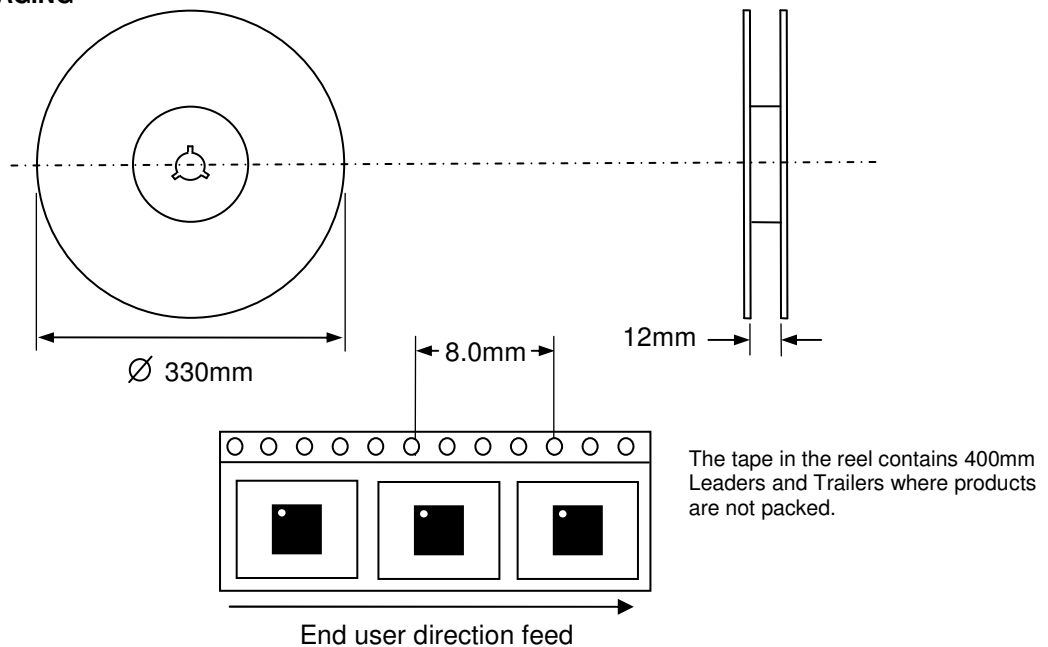

Figure 8: Tape Carrier Dimensions

ORDERING INFORMATION

Order Code	Package	Part Marking	Delivery	Quantity
5111	QFN	5111-ZZZZ	Tape and Reel	3000 ⁵

⁵ Sample quantities available in tubes