

The *Rejistor* is a precision-adjustable passive resistor enabling in-circuit, precision, analog calibration in a revolutionary way. Each *Rejistor* can be adjusted and fixed to 0.1% precision (or better) using electrical signals. The adjustment process provides precision control of the resistance of each resistor in the pair for set-on-test applications.

Precision adjustment of the resistance of each *Rejistor* is accomplished by means of a proprietary procedure which semi-permanently adjusts the resistive poly-silicon element in a closed-loop system under control of *Rejistor* Calibration tools and Rejust-it software. The adjustment process is typically complete within 1-2 seconds.¹

Adjustment changes the physical properties of the resistors. No external memory or boot-up is required. The material is physically altered to have a new electrical response. After adjustment, the *Rejistor* is stable in the range from -55°C to +125°C.

Resistance can be matched to within 0.1%, or better, of the target value. The *Rejistor* is ideal for gain setting, offset and bias adjustment, voltage adjustment and a variety of high-precision analog applications. The *Rejistor* features the lowest noise and the widest bandwidth of any adjustable resistor technology.

Each Low-TCR *Rejistor* is temperature stable, maintaining 0ppm/K ±100ppm/K TCR across the adjustment range. Relative TCR between both *Rejisters* is ±10ppm/K.

Rejisters are packaged in lead-free, RoHS and Green packages. The *Rejistor* is available in an 8-pin SOIC or a smaller 16-pin QFN package.

BENEFITS

- Precision electrical in-circuit adjustment
- Externally adjust or calibrate parameters on circuits or sensors at final assembly
- Adjustment process isolated from circuit allowing true in-circuit calibration
- Single chip solution to calibrate voltages, currents, offsets, gains, etc.
- No mechanical moving parts, ideal for vibration sensitive applications
- Improved reliability, dependability; dust and moisture resistance over mechanical parts
- Dynamic adjustment provides cost and labor savings
- Eliminates labor-intensive select-on-test adjustment
- Flexibility reduces rework cost
- Potential for multiple adjustments
- Lowest noise and widest bandwidth of any adjustable resistor technology
- In-circuit adjustment allows system calibration after encapsulation or packaging

ELECTRICALLY ADJUSTABLE 10KΩ 1:1 RESISTOR PAIR

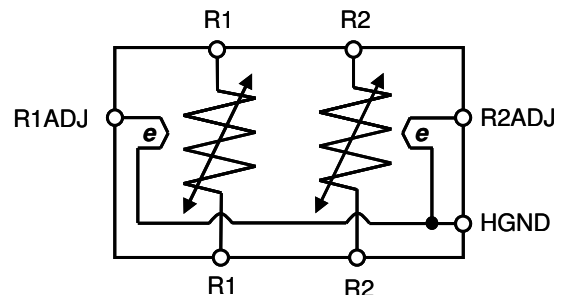

Figure 1: Functional Block Diagram

PARAMETER	SPECIFICATION
Resistance (as-manufactured)	10KΩ
Minimum adjustable resistance	7KΩ
Adjustment Precision	0.1% or 0.01% ¹
TCR	0±100ppm/K
Rated power (per <i>Rejistor</i>)	1mW (max)

FEATURES

- Each Resistor is independently electrically adjustable to any value from its as-manufactured value down 30% (e.g. 10KΩ down to 7KΩ), with accuracy 0.1% or better
- Bi-directional, continuous value adjustment within active range
- Long Term Stability 0.5%, see Table 5
- Stable Temperature Coefficient as resistance is adjusted - TCR: 0±100ppm/K
- Suitable for operation from -55 to +125°C, refer to Table 2
- Low noise: Typ. -15dB
- Passive device requires no power during operation
- In-circuit adjustable at wafer, component, board or system level
- QFN 16-pin and SOIC 8-pin package
- RoHS, Pb-free and green

APPLICATIONS

- Anywhere precision calibration is required
- Gain control and offset adjustment
- Reference voltage and current adjustment
- Precision Voltage Regulator calibration
- Filter tuning
- RF Amplifier biasing
- Opto-electronics
- Frequency Control devices
- Mechanical or digital potentiometer replacement
- Suitable for high-frequency applications

¹ Adjustment precision is limited by temperature control, accuracy of measurement and adjustment equipment and may increase adjustment time

Rejistor is a trademarks of Microbridge Technologies

Table 2: RATINGS – Rejustors $0^{\circ}\text{C} < T_A < +70^{\circ}\text{C}$ and rated power; unless otherwise noted.

Item	Conditions	Typical Specifications
Maximum Power		5 times rated power
Nominal Resistance R1		10,000Ω
R1 Rated Power		1.0mW
Operating Temperature	As specified in this datasheet	0°C to +70°C
	As specified in Application Note “ <i>Rejustor</i> Operating Guidelines for -55 to +125C Operation”	-55 to +125°C
	Beyond -55 to +125°C	Contact Microbridge
Isolation Voltage (between any pins)	Subject to power limits	25V
<i>Rejustor</i> Self-heating Coefficient of Resistance, R1		+2000 ppm/mW ±20%
<i>Rejustor</i> Self-heating Coefficient of Resistance, R2		+2000 ppm/mW ±20%
Relative Self-heating Coefficient of Resistance	When both <i>Rejustors</i> carry the same current	240 ppm/mW
Total Resistance Tolerance		As-manufactured resistance is ±10% from nominal
Nominal Adjustment range		+0 to -30% from as-manufactured
Nominal Pair Matching	Unadjusted	±2%

Table 3: TCR CHARACTERISTICS – Rejustors $0^{\circ}\text{C} < T_A < +70^{\circ}\text{C}$ and rated power; unless otherwise noted.

Characteristics	Specification (Worst Case)	Test Method or Conditions
Temperature Coefficient Unadjusted Adjusted	0±100ppm/K 0±100ppm/K	
Change in Temperature Coefficient	± 50ppm/K	TCR change in adjusted device relative to unadjusted device, by analysis
Temperature Coefficient Matching of pairs	± 10ppm/K	Adjusted to match resistance, by analysis
Divider Output Voltage Temperature Coefficient	± 15µV/V/K	By analysis, based on relative TCR

Table 4: PACKAGE ELECTRICAL CHARACTERISTICS

Characteristics	Specification (Typical)	Test Method or Conditions
SOIC Capacitive Loading	1.0pF	Per package pin, by analysis at 100MHz
SOIC Mutual Capacitance	0.1pF	By analysis at 100MHz
QFN Capacitive Loading	0.7pF	Per package pin, by analysis at 100MHz
QFN Mutual Capacitance	0.1pF	By analysis at 100MHz

Table 5: RELIABILITY DATA

Characteristics	Limit	Test Method or Conditions
Thermal Shock/ Cycling	+ 0.5% ²	JESD22-A104, -65°C to 125°C, 1000 cycles at 2 cycles/hour
Overload	+ 0.5% ²	MIL-R-55342H Par 4.8.6 (Rated Voltage x2.5, 5sec.), Rated voltage based on rated power $V = \sqrt{PR}$
High Temperature Exposure (long-term stability)	+ 0.5% ²	JESD22-A103 150°C, 1000hrs
Humidity and Moisture Resistance	+ 0.8% ²	JESD22-A101, 85% RH, 85°C, 1000hrs
Operational Life Test	+ 0.5% ²	JESD22-A108, 125°C, 1000 hrs., static operation at rated power
Shock	± 0.1%	500G, 1ms duration, X,Y,Z axes each 5 shocks
Vibration, High Frequency	± 0.1%	Max acceleration 20G, 20~2000~20Hz, 8 min, X,Y,Z each 4 sweeps

Table 6: MANUFACTURABILITY DATA

Characteristics	Test Method or Conditions
ESD Discharge	JESD22-A114, human body model weakest pin pair testing, all lead combinations. Class 1A
Solderability/Preconditioning	J-STD-020C, MSL1, 260°C convection reflow for SOIC-8 and QFN-16 packages

PACKAGING OPTIONS

Table 7: NOMINAL PACKAGE DIMENSIONS

Type	Lead Count	Body Width	Body Length	Lead Form	Tip to Tip	Body Thickness	Standoff	Overall Height	JEDEC/ EIAJ
SOIC	8	3.9mm	4.89mm	0.4mm	6.0mm	1.47mm	0.175mm	1.62mm	MS-012

Type	Lead Count	Body Width	Body Length	Lead Pitch	Lead Width	Lead Length	Body Thickness	JEDEC/ EIAJ
QFN	16	3.0mm	3.0mm	0.5mm	0.25mm	0.4mm	0.85mm	MO-220

² Where indicated, drift specifications refer to resistance drift in the positive direction. Best performance is achieved at adjustments larger than 10% down from the as-manufactured resistance.

APPLICATION EXAMPLES

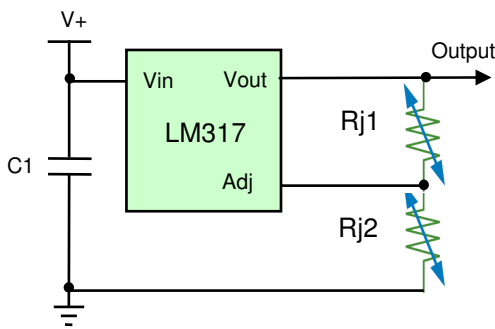

Figure 2: Voltage Regulator Application Circuit

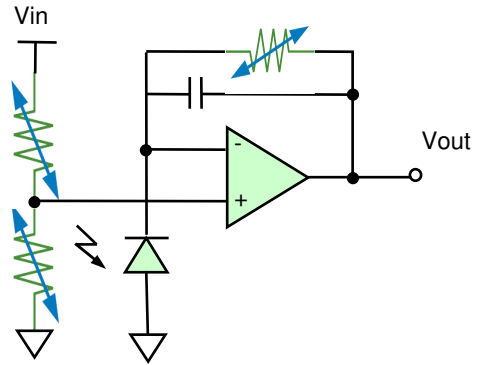

Figure 4: Adjustable Photo-Detector

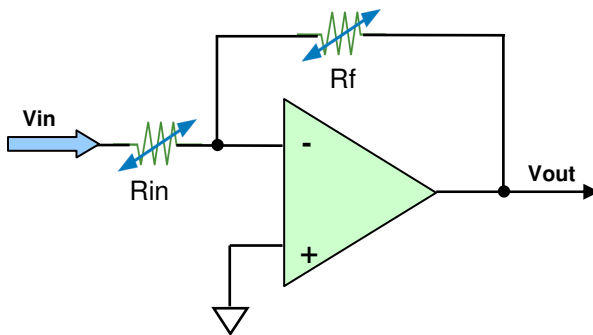

Figure 3: Basic Op Amp Application

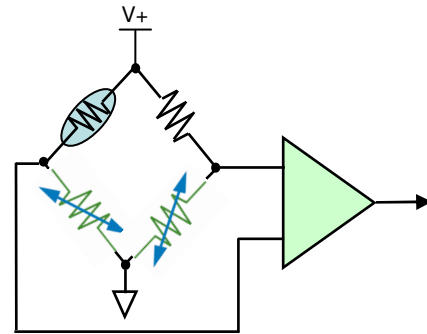

Figure 5: Sensor Offset Correction

FUNCTIONAL DESCRIPTION

Microbridge **Rejustors** represent a technology revolution in resistive adjustment for precision electronic systems. Each **Rejustor** in the dual package provides independent, precision adjustment of resistance in a continuous range for in-circuit, set-on-test adjustment of a wide variety of analog electronic circuits and systems.

Rejustors are adjusted in-circuit to meet the precision requirements of the application. For example, the **Rejustor** can be adjusted to provide an output voltage (Figure 2) or adjust a gain setting (Figure 3). In all cases, the exact resistance value of the **Rejustor** is less important than desired output parameters of the circuit being adjusted. The **Rejustor** is the only pure-passive resistive element that can be adjusted at final assembly, using only electrical signals. Furthermore, unlike laser-trimmed resistors, **Rejustors** can be adjusted bi-directionally.

Rejustors are adjusted using **Rejustor** Calibration Tools, such as the MBK-408A – Low cost, high-precision **Rejustor** Calibration tool. **Rejustors** can also be adjusted with a high-volume, high-precision Calibration tool based on the National Instruments NI-DAQ chassis.

During the calibration process, the **Rejustor** is connected to the **Rejustor** Calibration Tool, or equivalent hardware³. The Calibration tool provides the electrical connections to monitor the circuit output behavior and drive power into the Adjustment pins of the **Rejustor**. Power applied to the Adjustment pins controls the heating and cooling process which in-turn changes the resistance. Refer to Figure 6 for a sample connection between the MBK-408A **Rejustor** Calibration tool and the **Rejustor**. This connection to the calibration tool is only required during the adjustment step.

³ Using Microbridge’s scalable production-calibration hardware (based on the NI-DAQ platform from National Instruments) and Rejust-it software, multiple units can be calibrated simultaneously during roughly the same amount of time for high-volume applications.

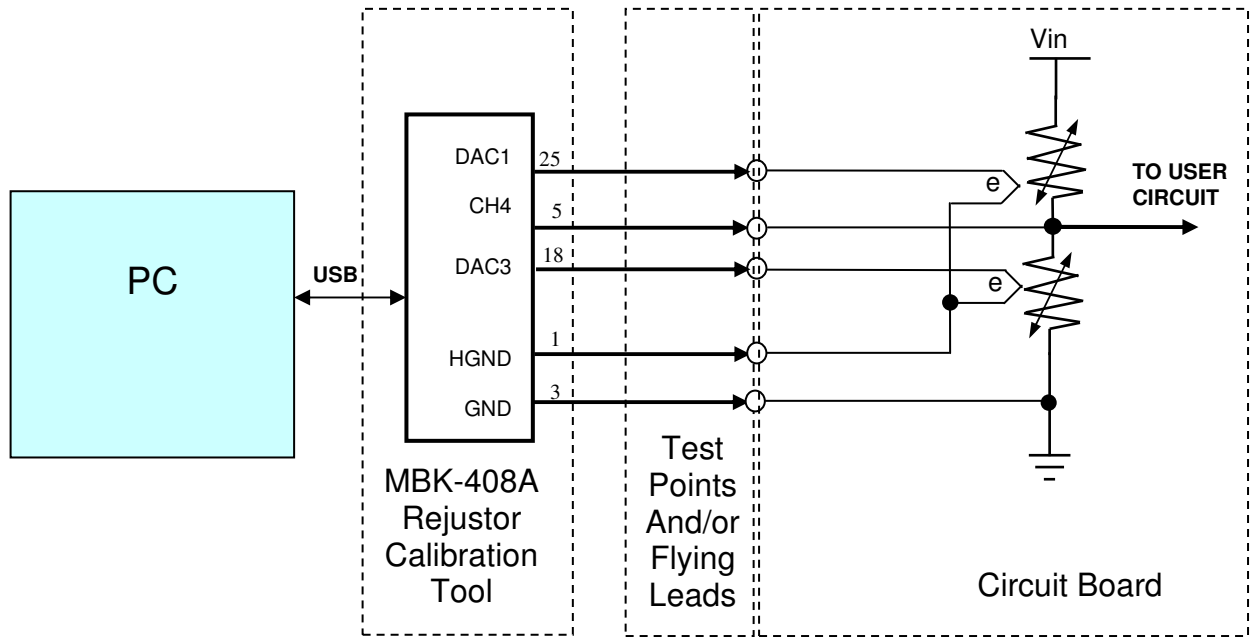

Figure 6: *Rejistor* Hardware Connection

Rejst-it software, provided as part of the *Rejistor* Calibration Tool is a LabVIEW-based executable and controls the adjustment process using the *Rejistor* Calibration Tool in a closed-loop feedback system. *Rejistors* are automatically adjusted to the target values, as specified in the graphical user interface. A sequence of electrical heating pulses, governed by Microbridge’s proprietary algorithms, is enough to fine-tune the material properties within approximately 1 second for most applications.

After adjustment, the circuit is disconnected from the *Rejistor* Calibration tool. The *Rejistor* does not require active power to maintain its adjusted resistance. The material properties of the *Rejistor* are altered to affect the current flow, which means the resistance is changed. *Rejistors* are intended for set-and-forget applications that involve factory calibration. The devices can be adjusted dozens-of-times, as may be required for periodic maintenance or calibration.

The resistive element of the Rejistor is electrically isolated from both substrate and Adjust (heater) pins and can therefore float, electrically.

Adjusted *Rejistors* are highly stable and retain their electrical and temperature performance characteristics indefinitely. *Rejistors* can be adjusted many times, bi-directionally without compromising stability or performance. *Rejistors* also feature the lowest noise and the widest bandwidth of any adjustable resistor technology.

Microbridge *Rejistors* are an electrical replacement for mechanical compensation techniques. They replace manual trim pots, digital pots and laser trimming. The Microbridge Technologies Low-TCR *Rejistor* family of electrically adjustable micro-resistors can be matched to values for precision control of sensors, voltage regulators, amplifiers and other applications.

PIN CONFIGURATION

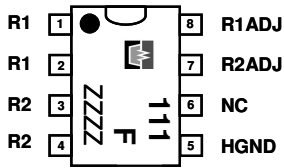

Figure 7: Pin Configuration, 8-lead SOIC package

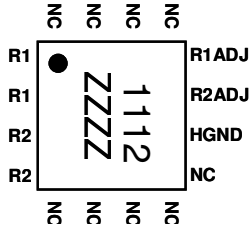

Figure 8: Pin Configuration, 16-pin QFN package (3x3mm)

PIN FUNCTIONAL DESCRIPTION

Table 8: Pin Function Descriptions

Mnemonic	Description	8-Pin SOIC Pin No.	16-Pin QFN Pin No.
R1	Rejutor 1 Terminal	1	1
R1	Rejutor 1 Terminal	2	2
R2	Rejutor 2 Terminal	3	3
R2	Rejutor 2 Terminal	4	4
HGND	Heater Ground	5	10
R2ADJ	Rejutor 2 Adjust Input	7	11
R1ADJ	Rejutor 1 Adjust Input	8	12
NC	No Connect	6	5, 6, 7, 8, 9, 13, 14, 15, 16

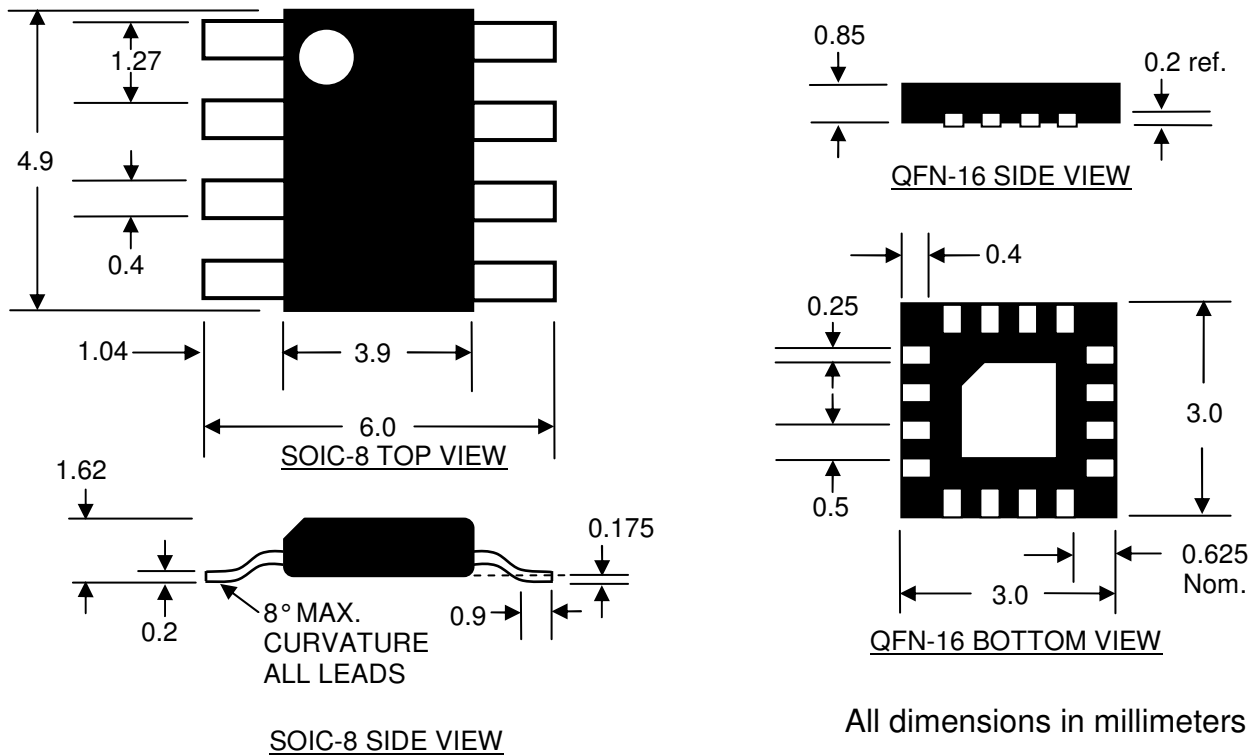

Figure 9: Package Dimensions

TAPE CARRIER PACKAGING

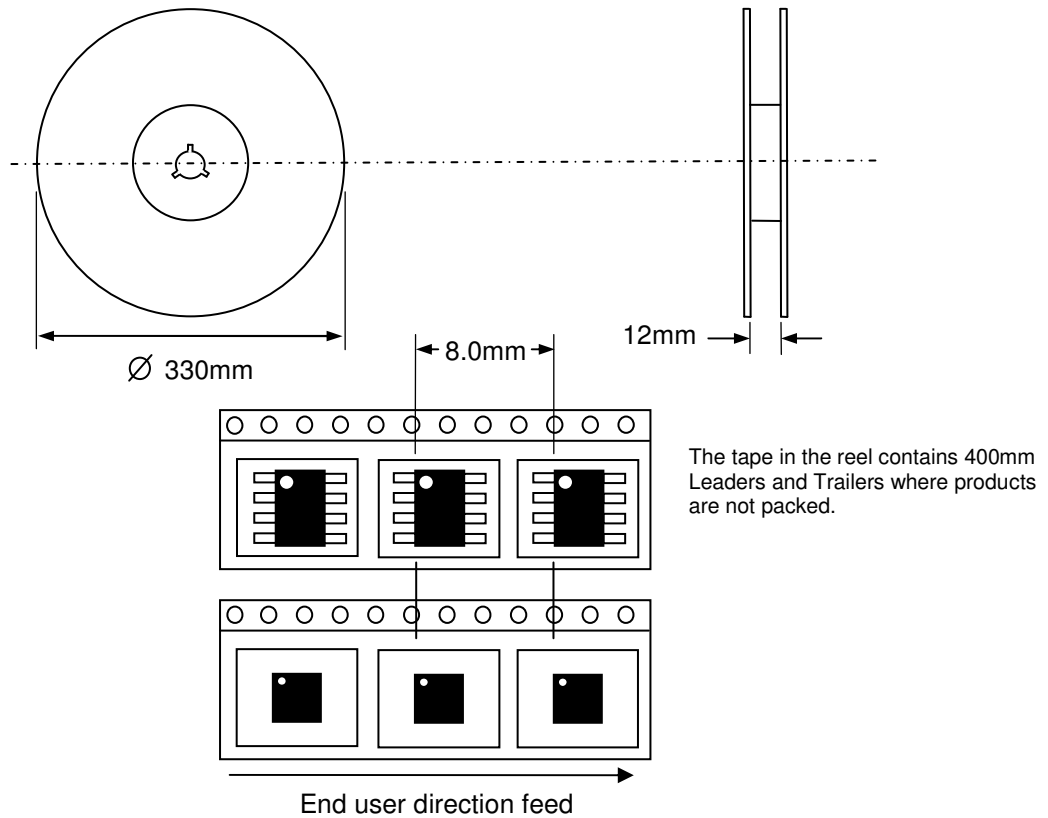

Figure 10: Tape Carrier Dimensions

Table 9: ORDERING INFORMATION

Part Number	Order Code	Package	Part Marking ⁴	Delivery	Quantity
MBD-103-AS	111F	SOIC-8	111F-ZZZZ	Tape and Reel	3000 ⁵
MBD-103-AS	1112	QFN	1112-ZZZZ	Tape and Reel	3000 ⁶

NOMINAL VALUES AVAILABLE

The following additional Dual **Rejutors** are available with similar performance specifications. Consult the individual datasheet for more information.

Part Number	Resistance R1 Value (Ω)	Resistance R2 Value (Ω)	Ratio	SOIC Order Code	QFN Order Code
MBD-472-AS	4700	4700	1:1	111E	1111
MBD-103-AS	10,000	10,000	1:1	111F	1112
MBD-103-BS	10,000	20,000	1:2	111H	1115
MBD-103-CS	10,000	50,000	1:5	111J	1117
MBD-103-ES	10,000	90,000	1:9	111L	1110
MBD-153-AS	15,000	15,000	1:1	111N	111C
MBD-903-AS	90,000	90,000	1:1	111P	111D

Please check with Microbridge Technologies Inc prior to design to ensure you have the latest revision of the datasheet for this part

⁴ Where ZZZZ represents the 4-digit date code

⁵ Sample quantities are available in tubes

⁶ Smaller sample quantities available on tape