

MB-LPS2-03-XXXX5N Series Differential Air Pressure Sensors Analog-Conditioned, Dynamic Range >10000x

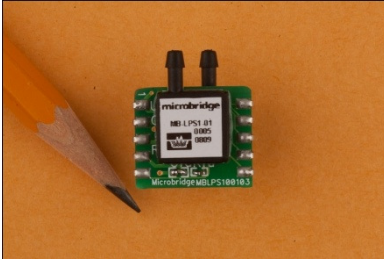

GENERAL DESCRIPTION

The MB-LPS2-03 series low-pressure sensors sense differential air (or other non-corrosive gas) pressure, inferring differential pressure from nano-liters per second gas-flow through an integrated air-flow channel having high flow-impedance. The transducer is a MEMS-based thermo-anemometer on a monolithic silicon chip. Rejutor technology combined with CMOS circuitry provides on-chip-integrated analog-only compensation and conditioning electronics. The chips are powered by 5V supply, with fixed (non-ratiometric) output voltage nominally 0.5V to 4.1V (unidirectional) or 0.7V to 4.3V (bidirectional).

FEATURES, BENEFITS

- Suitable to measure shunted- ΔP for flow-measurement systems being digitally calibrated after assembly.
- Dynamic Range greater than 10000x.
 - Excellent resolution (better than 0.01% of full-scale) at low ΔP , up to 20% of full-scale.
- High flow-impedance > 5 kPa/(ml/s).
 - Dominates flow-impedance in series (in-line) configurations.
 - Minimizes flow-through in bypass (parallel, shunt) configurations.
 - Allows use of filters and long connection hoses without losing calibration.
 - Immunity to dust and humidity.
- Rejutor-based analog-only on-chip signal conditioning electronics to compensate:
 - Offset, TC-Offset.
 - TC-Span in range up to 20% of full-scale.

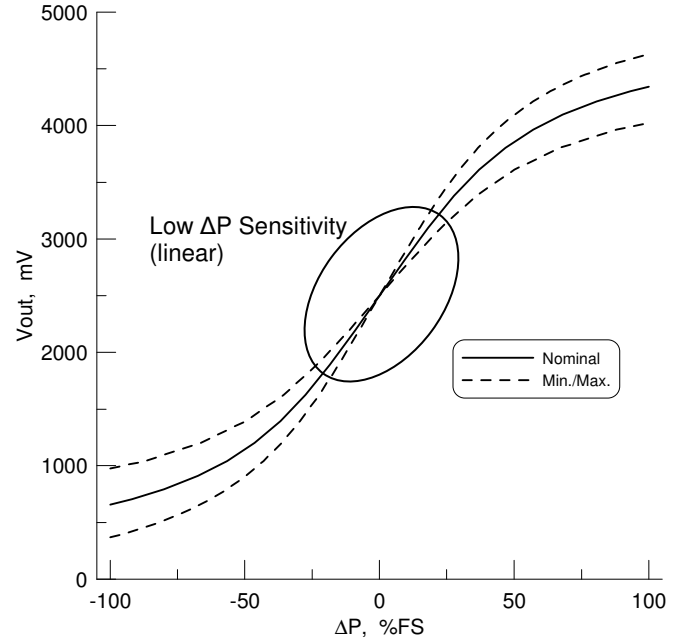

Fig. 1: Typical response for MB-LPS2-03 sensor.
Example: MB-LPS2-03-200B5N \rightarrow 2" H₂O, bidirectional.
Pneumatic impedance > 20kPa/(ml/s).

PRODUCT FAMILY: MB-LPS2-03-XXXX5N, FOR APPLICATIONS REQUIRING HIGH DYNAMIC RANGE > 10000x:

Part Number	Measurement Range (Full Scale Pressure Span)*			Nominal Low- ΔP ** Sensitivity***	Pneumatic Flow- Through Impedance
MB-LPS2-03-080B5N	+/-200 Pa	+/-0.8"H ₂ O	+/-0.029 PSI	18 mV/Pa	>5 kPa/(ml/s)
MB-LPS2-03-080U5N	0...200 Pa	0...0.8"H ₂ O	0...0.029 PSI	36 mV/Pa	>5 kPa/(ml/s)
MB-LPS2-03-100B5N	+/-250 Pa	+/-1"H ₂ O	+/-0.036 PSI	14.4 mV/Pa	>10 kPa/(ml/s)
MB-LPS2-03-100U5N	0...250 Pa	0...1"H ₂ O	0...0.036 PSI	28.8 mV/Pa	>10 kPa/(ml/s)
MB-LPS2-03-200B5N	+/-500 Pa	+/-2"H ₂ O	+/-0.072 PSI	7.2 mV/Pa	>15 kPa/(ml/s)
MB-LPS2-03-200U5N	0...500 Pa	0...2"H ₂ O	0...0.072 PSI	14.4 mV/Pa	>15 kPa/(ml/s)
MB-LPS2-03-500B5N	+/-1250 Pa	+/-5"H ₂ O	+/-0.180 PSI	2.9 mV/Pa	>30 kPa/(ml/s)
MB-LPS2-03-500U5N	0...1250 Pa	0...5"H ₂ O	0...0.180 PSI	5.8 mV/Pa	>30 kPa/(ml/s)

For other full-scale ranges, or asymmetric bidirectional measurement ranges, or other custom units \rightarrow Contact Microbridge

- * Note: 500 Pa = 2.010866"H₂O, which is approximated in this table as 2"H₂O and 0.072 PSI.
- ** See Fig. 1. Low- ΔP Sensitivity is the sensitivity at Low ΔP , (at applied pressures smaller than 20% of Full-Scale).
- *** MB-LPS2-03 series sensors are calibrated to give best resolution at low (small) ΔP , and linearity within 2% at low ΔP . Tolerances at larger ΔP , and up to Full-Scale, are wider. Actual Low- ΔP Sensitivity may vary from these nominal values by +/-20%.

Information furnished by Microbridge Technologies is believed to be accurate and reliable. However, no responsibility is assumed by Microbridge Technologies for its use, nor for any infringements of patents or other rights of third parties that may result from its use. Specifications subject to change without notice. No license is granted by implication or otherwise under any patent or patent rights of Microbridge Technologies. Trademarks and registered trademarks are the property of their respective companies.

SENSITIVITY AND SENSITIVITY TOLERANCE:

- Sensitivity of analog output voltage V_{out} to applied differential pressure (ΔP) has a generally non-linear curve, as exemplified in Figs. 1 (bidirectional) and 2 (unidirectional).
- Sensitivity (slope of V_{out} vs. ΔP) is greatest (steepest) at low (small) ΔP , and decreases for larger ΔP .
- Sensitivity at applied pressures smaller than $\pm 20\%$ of Nominal Full-Scale Span is linear within a tolerance of $\pm 2\%$ of Full-Scale. In other words, the curve is linear at small ΔP .
- The nominal sensitivity (slope) at applied pressures smaller than $\pm 20\%$ of Nominal Full-Scale Pressure Span is named “Nominal Low- ΔP -Sensitivity”, and is related to the sensor’s Nominal Full-Scale Span by the equation:

$$\text{Nominal Low}\Delta P\text{Sensitivity} = \frac{K \times (\text{Nominal FullScale Voltage Span, mV})}{(\text{Nominal FullScale Pressure Span, Pa})}$$

- ... where K is a parameter equal to 2;
- ... and where Nominal Full-Scale Output Voltage Span is:
 - Unidirectional sensor: 3600mV (from 0.5V to 4.1V, see Fig. 2);
 - Bidirectional sensor: 1800mV (from 2.5V to 4.3V, and from 2.5V to 0.7V, see Fig. 1).
- For example, for a unidirectional sensor with Nominal Full-Scale Pressure Span 500Pa, the Nominal Low- ΔP -Sensitivity = $[K \times (3600\text{mV}) / (500\text{Pa})] = 14.4\text{mV/Pa}$.
- For example, for a bidirectional sensor with Nominal Full-Scale Pressure Span 500Pa, the Nominal Low- ΔP -Sensitivity = $[K \times (1800\text{mV}) / (500\text{Pa})] = 7.2\text{mV/Pa}$.
- The sensor’s actual sensitivity at applied pressures smaller than $\pm 20\%$ of Nominal Full-Scale Pressure Span is named “Actual Low- ΔP -Sensitivity”, and is calibrated to within a tolerance of $\pm 20\%$ from the sensor’s “Nominal Low- ΔP -Sensitivity”, listed on p.1. In other words, the slope of the linear portion of the curve can vary by $\pm 20\%$ from its nominal value.
 - Following the example above, for a unidirectional sensor with Nominal Full-Scale Pressure 500Pa, the Actual Low- ΔP -Sensitivity is $14.4\text{mV/Pa} \pm 20\%$, which corresponds to 11.5mV/Pa to 17.3mV/Pa .
- The Output Voltage at Nominal Full-Scale ΔP is calibrated to within $\pm 17\%$ from Nominal Full-Scale Voltage Span listed above. In other words, the Output Voltage Span can vary:
 - between 3000mV and 4200mV for unidirectional sensors (see Fig. 2).
 - between 1500mV and 2100mV for bidirectional sensors (see Fig. 1).
 - This variation is due to variation in non-linearity at large ΔP , and due to the above-described variations in Actual Low- ΔP -Sensitivity.

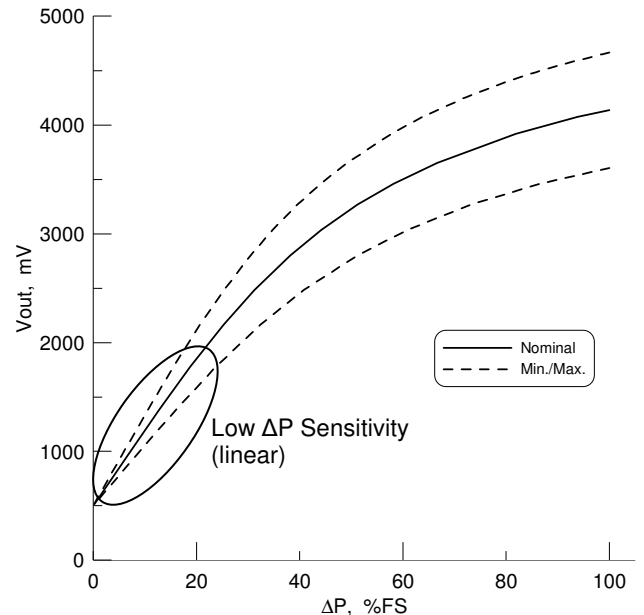

**Fig. 2: Typical response for MB-LPS2-03 sensor.
Example: MB-LPS2-03-200U5N →2”H₂O, unidirectional.**

PRESSURE NON-LINEARITY:

The MB-LPS2-03 series sensors’ output voltage vs. ΔP behaviour has significant non-linearity with a known approximate basic shape, as illustrated in Fig. 1 on p.1 (for bidirectional sensors), and as illustrated in Fig. 2 (for unidirectional sensors). The curve of output voltage (V_{out}) vs. differential pressure (ΔP), is close to linear at low-magnitude differential pressures, and becomes progressively more non-linear at high differential pressures. As shown in Fig. 2, the downward curvature grows smoothly as the magnitude of applied pressure increases. As shown in Fig. 1, for negative differential pressures, the curvature is upward.

Since the intent of the sensor is to allow the user to infer ΔP from a V_{out} reading, the nominal characteristic curve is described (approximated) by ΔP as a function of V_{out} :

Information furnished by Microbridge Technologies is believed to be accurate and reliable. However, no responsibility is assumed by Microbridge Technologies for its use, nor for any infringements of patents or other rights of third parties that may result from its use. Specifications subject to change without notice. No license is granted by implication or otherwise under any patent or patent rights of Microbridge Technologies. Trademarks and registered trademarks are the property of their respective companies.

$$\Delta P = \frac{(\text{Actual Low}\Delta P\text{Sensitivity}) \times |(V_{out} - V_o - \text{ZeroOffset})|}{1 - \left(\frac{|V_{out} - V_o - \text{ZeroOffset}|}{V_{sat}}\right)^N}$$

where:

- **V_{out}** is the output voltage, in mV.
- **V_o** is the nominal output voltage at zero sensor stimulus, i.e. +0.5V for unidirectional sensors, and +2.5V for bidirectional sensors.
- **ZeroOffset** is as specified in Table 1 (Unidirectional) and Table 2 (Bidirectional).
- **Actual Low ΔP Sensitivity** is the actual slope of the sensor's response, in mV/Pa, at Low ΔP (ΔP smaller than 20% of Full-Scale).
 - Within +/-20% from Nominal Low ΔP Sensitivity, defined earlier.
- **ΔP** is the applied differential pressure, in Pa.
- **V_{sat}** is a positive fitting constant approximately 5 to 6 V (for unidirectional sensors) and approximately 2 to 4 V (for bidirectional sensors), at which V_{out} would be expected to saturate.
- **N** is another positive fitting constant, affecting the curvature of V_{out} vs. ΔP , near Full-Scale. As N decreases, the curvature increases. For these sensors having dynamic range >10000x, N is between 2 and 3. The behavior of individual sensor units follows this typical form of non-linear curve.
 - This curvature near Full-Scale has some tolerance, which contributes to the tolerance of Full-Scale output voltage Span, at Full-Scale Pressure.

Figs. 3 and 4 show examples of the deviation from linearity for bidirectional (Fig. 3) and unidirectional (Fig. 4) sensors. At low ΔP , the response is linear, corresponding to the Actual Low- ΔP -Sensitivity, and the deviation from linearity increases as the applied ΔP becomes larger (in both positive and negative directions for bidirectional sensors). In Fig. 4, for unidirectional sensors with K = 2, at Full-Scale pressure the deviation is approximately minus-100% of Full-Scale, with some tolerance about this nominal value. In Fig. 3, an example of a bidirectional sensor is shown. Note that the deviations of V_{out} from perfect linearity are calculated as a percentage of Nominal Full-Scale Voltage Span. The reference line from which the deviations are calculated is the Actual Low- ΔP -Sensitivity.

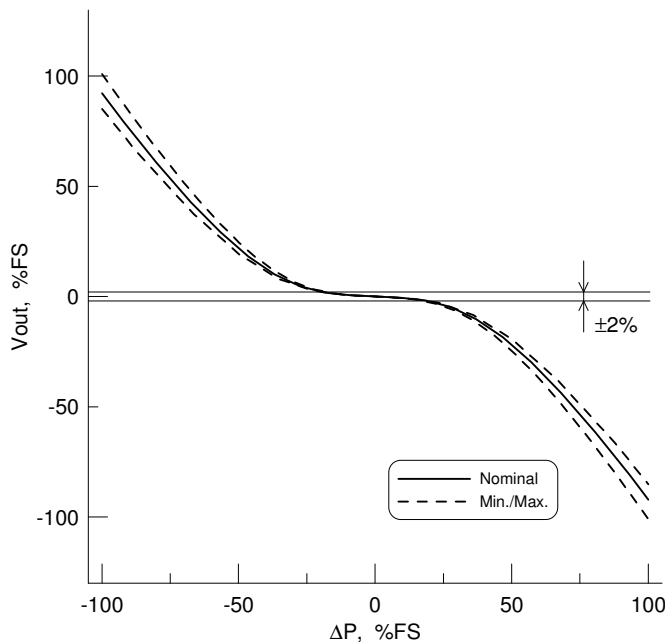

Fig. 3: Typical deviation from linearity for MB-LPS2-03 sensor. Deviation is calculated with respect to the straight line corresponding to Nominal Low- ΔP -Sensitivity. Example: MB-LPS2-03-200B5N \rightarrow 2" H₂O, bidirectional.

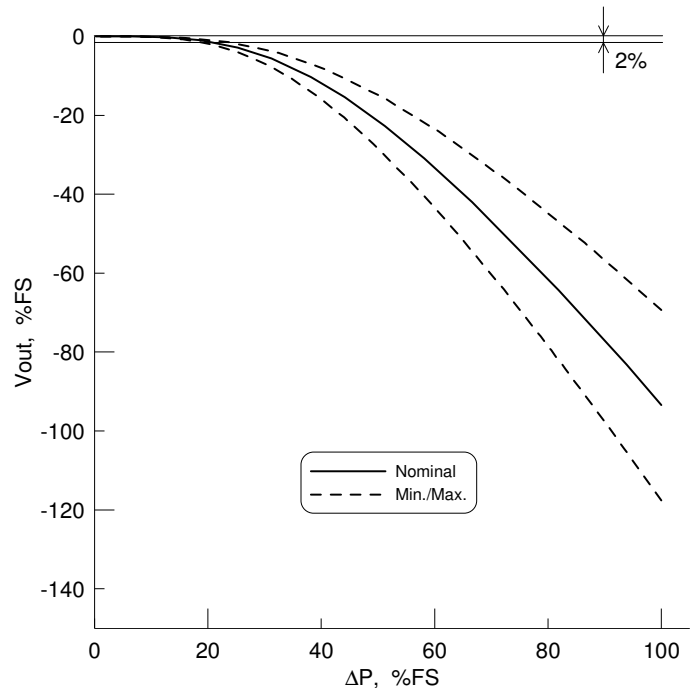

Fig. 4: Typical deviation from linearity for MB-LPS2-03 sensor. Deviation is calculated with respect to the straight line corresponding to Nominal Low- ΔP -Sensitivity. Example: MB-LPS2-03-200U5N \rightarrow 2" H₂O, unidirectional.

Information furnished by Microbridge Technologies is believed to be accurate and reliable. However, no responsibility is assumed by Microbridge Technologies for its use, nor for any infringements of patents or other rights of third parties that may result from its use. Specifications subject to change without notice. No license is granted by implication or otherwise under any patent or patent rights of Microbridge Technologies. Trademarks and registered trademarks are the property of their respective companies.

SENSITIVITY AND SPAN SHIFT OVER TEMPERATURE:

The sensitivity of MB-LPS2-03 series sensors is temperature-compensated to typically $\pm 2\%$ in the Low- ΔP range up to $\pm 20\%$ of Full-Scale pressure span, where the output voltage is fairly linear with applied pressure. The sensor's output voltage span in the upper pressure range, from $\pm 20\%$ to $\pm 100\%$ of Full-Scale pressure span, is not temperature-compensated, and can vary typically up to $\pm 15\%$ as the ambient temperature changes. As shown in Fig. 5, below, the curvature of V_{out} vs. ΔP decreases at high temperatures and increases at low temperatures.

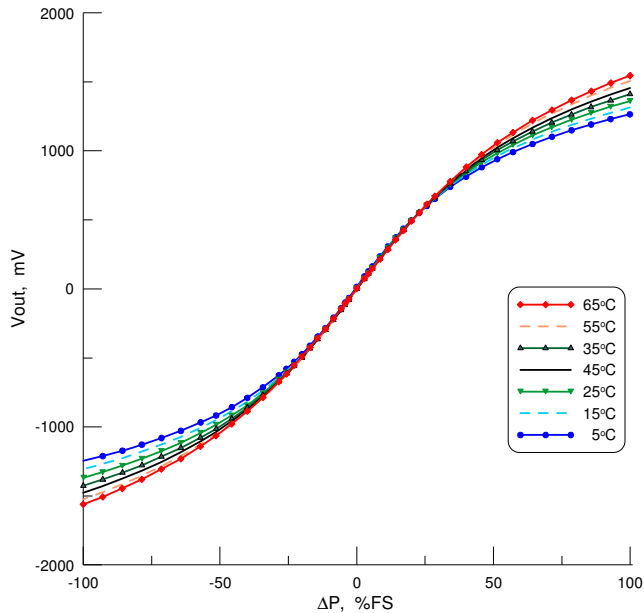

Fig. 5: Typical deviation of V_{out} vs. ΔP with temperature for MB-LPS2-03 sensors. While all curves, from 5°C to 65°C coincide at Low- ΔP , up to $\pm 20\%$ of Full-Scale pressure span, the curves then diverge to a wider tolerance at \pm Full-Scale pressure span.

Example: MB-LPS2-03-200B5N \rightarrow 2" H₂O, bidirectional.

**TABLE 1: MB-LPS2-03-XXXU5N SPECIFICATIONS:
ANALOG-CONDITIONED LOW DIFFERENTIAL AIR PRESSURE SENSOR (UNDIRECTIONAL)**

Characteristic	Specification
Excitation voltage	$V_{DD} = 5$ VDC (min 4.75V, max 5.25V) (V_{DD} power supply must be externally regulated)
Current consumption	Typ. 4.0 mA (no load)
Output Impedance	Max less than 100 Ω
Minimum output load resistance	5k Ω m (less than 1 mA output drive current)
Nominal Output Voltage (with $V_{DD} = 5$ VDC)	MB-LPS2-03-XXXU5N: +0.5V (at zero-Pressure); +4.1V (at Full Scale pressure)
Nominal Full-Scale Output Voltage Span (with $V_{DD} = 5$ VDC)	+3.6V (3600 mV)
Calibrated Zero Offset	Smaller than +/-10mV
Zero Offset Warmup Shift	Smaller than +/-2mV
Differential Pressure Resolution	Smaller than 0.01% Full Scale, at low ΔP up to 20% of Full Scale pressure (minimum detectable differential pressure). Smaller than 0.1% Full Scale, at high ΔP (near Full-Scale pressure)
Sensitivity at Low ΔP (Low- ΔP -Sensitivity) (See Fig. 2.)	See Nominal values in Product Family Table on p.1, and definition of K below. = [K x (nominal FS voltage span, mV) / (nominal FS pressure span, Pa)] (This is sensitivity at $\leq 20\%$ Full-Scale pressure, where $V_{out} \approx +0.5V$ to +1.5V)
Actual Low- ΔP -Sensitivity	A straight line fitted to actual sensor response at applied pressures below 20% of Full-Scale.
Tolerance of Actual Low- ΔP -Sensitivity vs. Nominal Low- ΔP -Sensitivity	Within +/-20% deviation from Nominal Sensitivity at Low- ΔP (5 $^{\circ}$ C to 55 $^{\circ}$ C)
Nominal K factor	K=2 Note: K is a factor determined by Microbridge to set the dynamic range of the sensor. For sensors with linear analog output throughout the measurement range, $K=1$. As K increases, the dynamic range, non-linearity, tolerance at Full-Scale and span temperature-shift also increase. Higher dynamic ranges correspond to greater Low- ΔP -Sensitivity, for a given Full-Scale Pressure Span.
Non-Linearity (measured as deviation from Actual Low- ΔP -Sensitivity)	Within -2% to +0.5% of Nominal Full-Scale Voltage Span, at applied pressures up to 20% of Full-Scale (5 $^{\circ}$ C to 55 $^{\circ}$ C) Typ. approx minus-100% of Nominal Full-Scale Voltage Span, near 100% of Full-Scale pressure (at 23 $^{\circ}$ C). Note: The non-linear curve has characteristic shape as exemplified in Fig. 2, and deviation from the Actual Low- ΔP -Sensitivity line has characteristic shape, exemplified Fig. 4.
Tolerance of Output Voltage at Nominal Full-Scale ΔP (See Figs. 2 and 4.)	Within +/-17% of Full-Scale Output Voltage Span (at 23 $^{\circ}$ C)
Zero Offset Temperature Shift	Smaller than +/-10mV (5 $^{\circ}$ C to 55 $^{\circ}$ C)
Low- ΔP -Sensitivity Shift Over Temperature (See Fig. 5.)	Typ. +/-2%, at applied pressures up to 20% of Full-Scale (5 $^{\circ}$ C to 55 $^{\circ}$ C)
Span Shift Over Temperature (See Fig. 5.)	Typ. +/-15% of Nominal Full-Scale output voltage, near 100% of Full-Scale pressure (5 $^{\circ}$ C to 55 $^{\circ}$ C). Note: curvature decreases at high temperatures and increases at low temp's.
Output Noise	Typ. 1mV p-p
Response Time	Typ. 2ms
Burst Pressure	Greater than 5 atmospheres
ESD protection	2000V HBM – JESD22-A114, human body model weakest pin pair testing, all lead combinations, Class 2.
RoHS compliant	

Information furnished by Microbridge Technologies is believed to be accurate and reliable. However, no responsibility is assumed by Microbridge Technologies for its use, nor for any infringements of patents or other rights of third parties that may result from its use. Specifications subject to change without notice. No license is granted by implication or otherwise under any patent or patent rights of Microbridge Technologies. Trademarks and registered trademarks are the property of their respective companies.

**TABLE 2: MB-LPS2-03-XXXB5N SPECIFICATIONS:
ANALOG-CONDITIONED LOW DIFFERENTIAL AIR PRESSURE SENSOR (BIDIRECTIONAL)**

Characteristic	Specification
Excitation voltage	$V_{DD} = 5$ VDC (min 4.75V, max 5.25V) (V_{DD} power supply must be externally regulated)
Current consumption	Typ. 4.0 mA (no load)
Output Impedance	Max less than 100 Ω
Minimum output load resistance	5k Ω m (less than 1 mA output drive current)
Nominal Output Voltage (with $V_{DD} = 5$ VDC)	MB-LPS2-03-XXXB5N: +0.7V (at negative Full Scale pressure); +2.5V (at zero-Pressure); +4.3V (at positive Full Scale pressure) Asymmetric bidirectional measurement ranges are also possible → Contact Microbridge.
Nominal Full-Scale Span (with $V_{DD} = 5$ VDC)	Output Voltage Span: +/-1.8V (defined as 1800 mV) Pressure Span: (magnitude of positive span) = (magnitude of negative span) (e.g. +/-500Pa → Full-Scale Pressure Span is defined to be 500Pa)
Calibrated Zero Offset	Smaller than +/-8mV
Zero Offset Warmup Shift	Smaller than +/-2mV
Differential Pressure Resolution	Smaller than 0.01% of Full Scale pressure, at low ΔP near $V_{out} = 2.5$ V, up to +/-20% of Full Scale pressure (minimum detectable differential pressure). Smaller than 0.1% Full Scale pressure, at high ΔP (near +/-Full-Scale pressure)
Sensitivity at Low ΔP (Low- ΔP -Sensitivity) (See Fig. 1.)	See Nominal values in Product Family Table on p.1, and definition of K below. = [K x (nominal FS voltage span, mV) / (nominal FS pressure span, Pa)] (This is sensitivity at $\Delta P < +/-20\%$ of Full-Scale pressure, near $V_{out} = 2.5$ V)
Actual Low- ΔP -Sensitivity	A straight line fitted to actual sensor response at applied pressures smaller than 20% of Full-Scale.
Tolerance of Actual Low- ΔP -Sensitivity vs. Nominal Low- ΔP -Sensitivity	Within +/-20% deviation from Nominal Sensitivity at Low- ΔP (5°C to 55°C).
Nominal K factor	K=2 Note: K is a factor determined by Microbridge to set the dynamic range of the sensor. For sensors with linear analog output throughout the measurement range, K=1. As K increases, the dynamic range, non-linearity, tolerance at Full-Scale and span temperature-shift also increase. Higher dynamic ranges correspond to greater Low- ΔP -Sensitivity, for a given Full-Scale Pressure Span.
Non-Linearity (measured as deviation from Actual Low- ΔP -Sensitivity)	Within +/-2% of Nominal Full-Scale Voltage Span, at applied pressures up to 20% of Full-Scale (5°C to 55°C). Typ. approx. minus-100% of Nominal Full-Scale Voltage Span, near 100% of Full-Scale pressure (at 23°C). <u>Note:</u> The non-linear curve has characteristic shape as exemplified in Fig. 1, and deviation from the Actual Low- ΔP -Sensitivity line has characteristic shape, exemplified in Fig. 3.
Tolerance of Output Voltage at Nom. Full-Scale ΔP (Figs. 1, 3)	Max. within +/-17% of Nominal Full-Scale Output Voltage Span (at 23°C)
Zero Offset Temperature Shift	Smaller than +/-7mV (5°C to 55°C)
Low- ΔP -Sensitivity Shift Over Temperature (See Fig. 5.)	Typ. +/-2%, up to +/-20% of Full-Scale pressure (5°C to 55°C)
Span Shift Over Temperature (See Fig. 5.)	Typ. +/-15% of Nominal Full-Scale output voltage, near +/-100% of Full-Scale pressure (5°C to 55°C). Note: curvature decreases at high temp's and increases at low temp's.
Output Noise	Typ. 1 mV p-p
Response Time	Typ. 2ms
Burst Pressure	Greater than 5 atmospheres
ESD protection	2000V HBM – JESD22-A114, human body model weakest pin pair testing, all lead combinations, Class 2.
RoHS compliant	

Information furnished by Microbridge Technologies is believed to be accurate and reliable. However, no responsibility is assumed by Microbridge Technologies for its use, nor for any infringements of patents or other rights of third parties that may result from its use. Specifications subject to change without notice. No license is granted by implication or otherwise under any patent or patent rights of Microbridge Technologies. Trademarks and registered trademarks are the property of their respective companies.

IMMUNITY TO RFI:

Test	Result
Sweep 80MHz - 2.7GHz	<ul style="list-style-type: none"> Less than 0.5% error for any package orientation subjected to 10V/m electric field (by analysis).

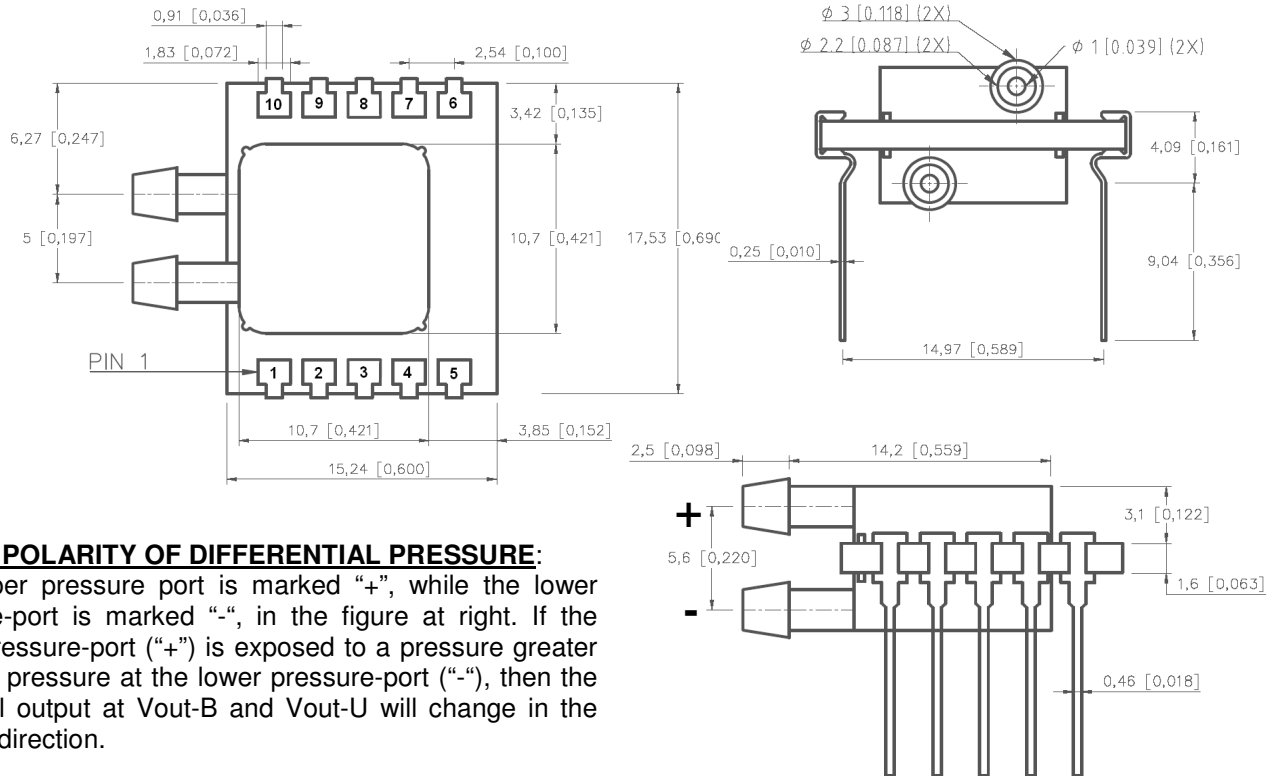
PACKAGE AND PINOUT INFORMATION:**ABOUT POLARITY OF DIFFERENTIAL PRESSURE:**

The upper pressure port is marked “+”, while the lower pressure-port is marked “-”, in the figure at right. If the upper pressure-port (“+”) is exposed to a pressure greater than the pressure at the lower pressure-port (“-“), then the electrical output at Vout-B and Vout-U will change in the positive direction.

Pin #	Name	Function
1	GND	Main circuit ground for the power supply and analog circuit
2	VDD	Main circuit power supply
3	Vout-B	Output voltage for bidirectional-mode sensors (calibrated in MB-LPS2-03-XXXB5N units)
4	Vout-U	Output voltage for unidirectional-mode sensors (calibrated in MB-LPS2-03-XXXU5N units)
		Note: A subset of the above pins are the only pins used during normal functioning of the sensor (GND, VDD and <i>either</i> Vout-B <i>or</i> Vout-U).
5		Should be connected to ground by the user.
6		Should be connected to ground by the user.
7		Should be connected to ground by the user.
8		Should be connected to ground by the user.
9		Should be connected to ground by the user.
10		Should be connected to ground by the user.
		Note: pins # 5 – 10 should be connected to ground by the user, but no current will be flowing through them in normal operation.

Information furnished by Microbridge Technologies is believed to be accurate and reliable. However, no responsibility is assumed by Microbridge Technologies for its use, nor for any infringements of patents or other rights of third parties that may result from its use. Specifications subject to change without notice. No license is granted by implication or otherwise under any patent or patent rights of Microbridge Technologies. Trademarks and registered trademarks are the property of their respective companies.

RECOMMENDED OUTPUT VOLTAGE FILTERING:

It is recommended for normal usage that the output of the sensor be connected through an RC low-pass filter as shown in the circuit diagram below. The choice of low-pass cutoff frequency can be made according to the desired response-time.

Note that this filter is connected during calibration of the sensors, with $R_{filter} \sim 5k\Omega$ and $C_{filter} \sim 100nF$.

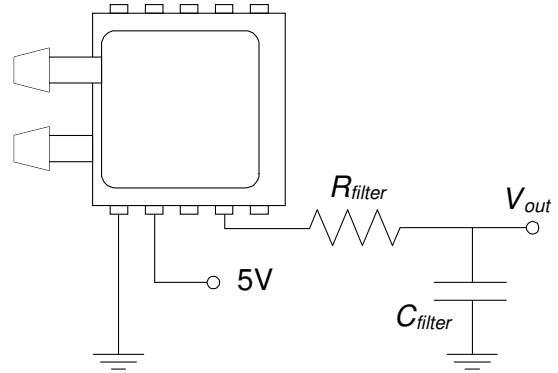
**STANDARD ALTITUDE CORRECTION:**

Variations in ambient atmospheric pressure (caused by elevation with respect to sea level), need to be compensated externally to the sensor, according to a simple mathematical expression:

$$True\Delta P = \frac{(Sensor\Delta P) \times (1.00 Bar)}{(AmbientPabs)}$$

where:

True ΔP : altitude-adjusted differential pressure

Sensor ΔP : sensor's differential pressure as indicated by the output voltage

AmbientPabs : actual ambient absolute pressure (measured in bars)

Note: Units are calibrated such that True ΔP will equal the Sensor ΔP when the ambient pressure is 1.00 bar.

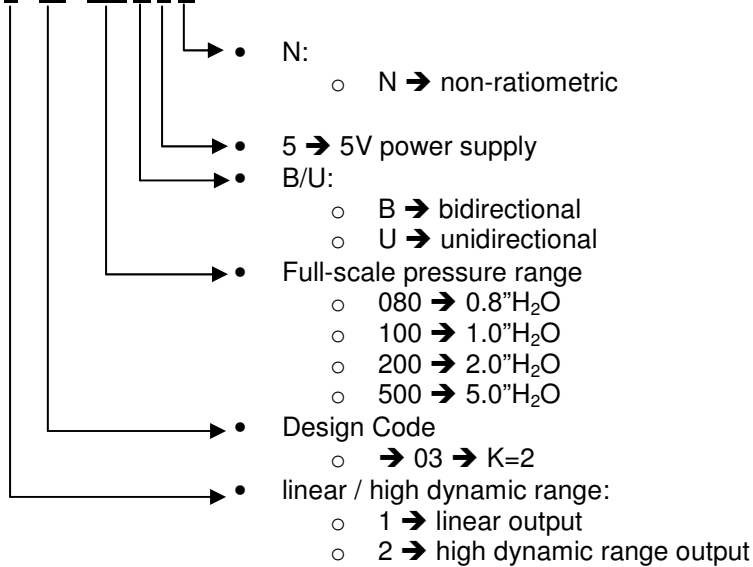
PART NUMBER NAMING CONVENTION:**MB - LPS 2 - 03 - 100 B 5 N****REVISION HISTORY:**

- Based on Product Concept MB-LPS2-02-XXXX5N, Rev. 2.2, May 28, 2010.
- MB-LPS2-03-XXXX5N, Rev 1.01, November 30, 2010. Status as Product Concept and Preliminary Engineering Samples is removed – the product is now available with K ~ 2 (tolerance 1.6 to 2.4), corresponding to Design Code 03. Output voltage range in the first paragraph on p.1 is made consistent with Tables 1 and 2. Typical current consumption is changed from 3.5mA to 4.0mA. In Tables 1 and 2, the definitions/specifications of K and Low- ΔP -Sensitivity are changed for further clarity. The tolerance of Low- ΔP -Sensitivity is +/-20% from Nominal. At applied pressures smaller than 20% of full scale, non-linearity is better than 2%. The tolerance of Output Voltage at Full-Scale ΔP is +/-17%. A noise specification is added to Tables 1 and 2. Explanatory examples are changed.