

Pressure Catheter

Passive Compensation Solution for Pressure Catheter Applications

1 Introduction

Pressure catheters are used for a variety of medical and laboratory monitoring applications. Three critical factors affecting catheter design are size, accuracy and temperature immunity. **Rejustors** are an effective passive compensation solution for catheter-tip sensors that incorporate micro-pressure sensors that are inserted into a body cavity duct or vessel.

This application note describes the process to compensate span, offset and temperature coefficient of offset for pressure catheters using **Rejustors**. The design is based on the SM5108 Miniature Piezo-resistive Pressure Sensor from Silicon Microstructures (SMI) and the MBN-2108 from Microbridge. A similar approach may be used with any miniature pressure sensor die and the MBN-2108. Implementing this design results in a high-quality, reliable product which is robust and manufacturable.

The MBN-2108 Compensation **Rejustor** works with a split-bridge. It compensates offset and TC_Offset for sensors with a nominal resistance from 3500 Ω to 7000 Ω . It converts a sensor with sensitivity from 16 to 34 $\mu\text{V}/\text{V}/\text{K}$ into a compensated sensor which meets the 5 $\mu\text{V}/\text{V}/\text{mmHg}$ sensor standard sensitivity specification for catheter applications.

1.1 Background

Rejustors are an excellent method for in-circuit compensating Wheatstone Bridge sensors. The resistive element in the **Rejustor** is a simple passive, bi-directionally adjustable resistor with behavior and precision similar to a thin-film resistor.

Rejustor-based passive temperature compensation reduces the temperature induced drift of the sensor by up to several orders of magnitude. It is not necessary to explicitly sense the temperature of the sensor during operation, allowing the catheter to remain at minimum size. The configuration described herein also reduces the number of connections required to the catheter sensor.

The SM5108 is an extremely small (0.65 mm x 0.65 mm) silicon micro-machined Piezo-resistive pressure sensing chip that has been optimized to provide the high accuracy for a die of this size. This performance is achieved through careful resistor placement and mechanical configuration. A catheter can be assembled approximately 2 French (0.64mm) in diameter using this sensor.

2 General Overview

Microbridge Wheatstone Bridge compensation **Rejustors** are ideally suited for disposable and re-usable pressure sensors in catheter applications. The **Rejustor** network can compensate offset, temperature coefficient of offset (TC_Offset) and sensitivity. The result is a stable sensor for applications with 5 $\mu\text{V}/\text{V}/\text{mmHg}$ monitoring systems.

The compensation scheme used by the **Rejistor** network does not require maintaining the sensor and the compensation network at the same temperature, nor to explicitly monitor the temperature of the sensor. Temperature induced drift in the sensor is effectively eliminated without sacrificing performance. Because of this strategy, the **Rejistor** network can be installed in the connector, operating at room temperature, while the sensor is exposed to wider temperature ranges without degrading the accuracy of the measurement. This method is referred to as Bridge-sensor compensation/conditioning using a non-local **Rejistor** network. Note that the sensor and the **Rejistor** network are not necessarily at the same temperature, yet the overall assembly meets the temperature drift requirements.

3 Bridge-Sensor Compensation/Conditioning Using Non-local **Rejistor** Network

The compensation scheme of the catheter pressure sensor is shown in Figure 1. Six adjustable resistors are placed outside of the catheter and operate at constant or nearly constant temperature, (near room temperature). Therefore even if they have non-zero TCR, their resistance stays relatively constant even as the local temperature of the catheter tip varies. Note that a split-bridge configuration is recommended to improve noise immunity.

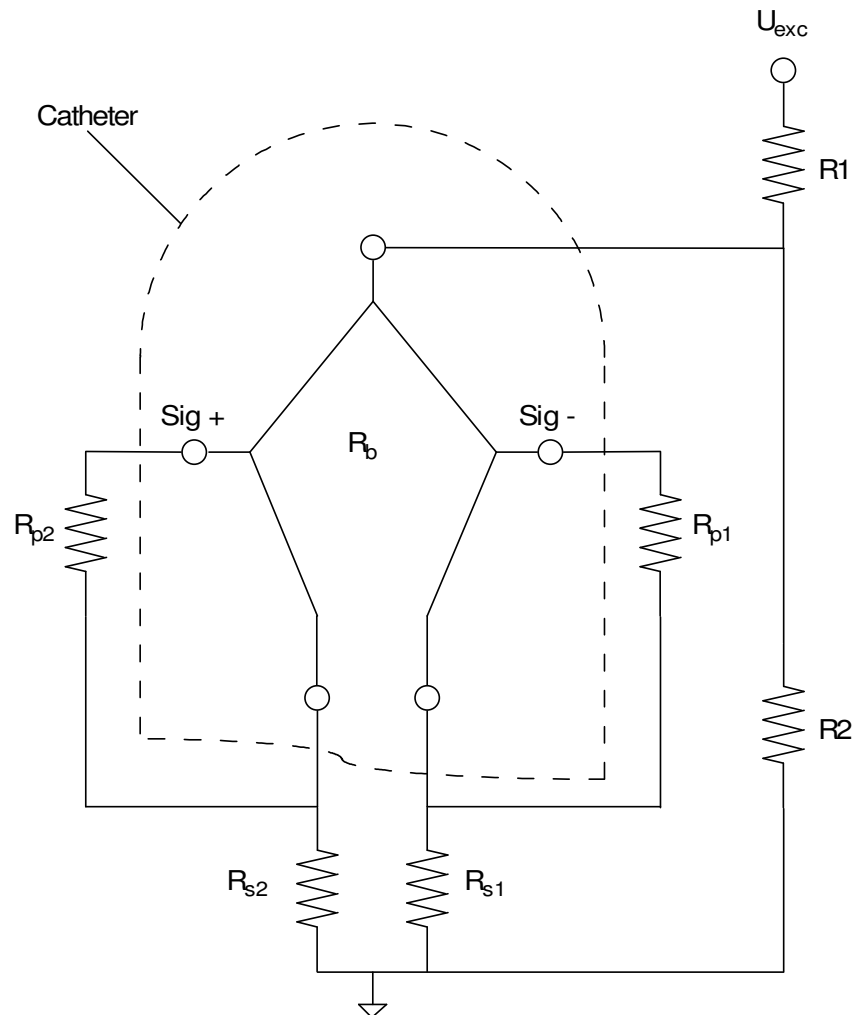

Figure 1: Catheter Schematic Representation

3.1 Offset and TC_Offset Compensation

First consider the simple resistor network shown in Figure 2. R_b is a bridge resistor. Resistors with zero-TCR $R_p = 10R_b$ and $R_s = 0.1R_b$ are connected in parallel and in series with resistor R_b , which has $TCR = 3000\text{ppm/K}$. Reducing the resistance of each of the resistors, R_s and R_p , results in decreased overall network resistance and a shift of its overall TCR, as shown in Figure 3. Reducing R_s results in increased overall TCR while reducing R_p results in decreased overall TCR.

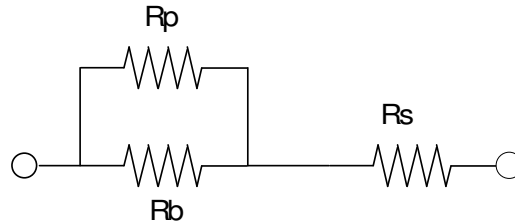

Figure 2: Resistor Network

Analogously, reducing the resistance of resistors R_{s1} , R_{s2} , R_{p1} and R_{p2} (Figure 1) results in resistance mismatch of two branches of the sensor bridge (Offset adjustment), and relative TCR mismatch (TC_Offset adjustment) as shown in Figure 4. This four-resistor **Rejustor** network with $R_{s1} = R_{s2} = 0.1R_b$ and $R_{p1} = R_{p2} = 10R_b$ allows Offset and TC_Offset adjustment in the range $\pm 10\text{mV/V}$ and $\pm 25\mu\text{V/V/K}$ respectively. This adjustment range is sufficient for compensation of SM5108 pressure die.

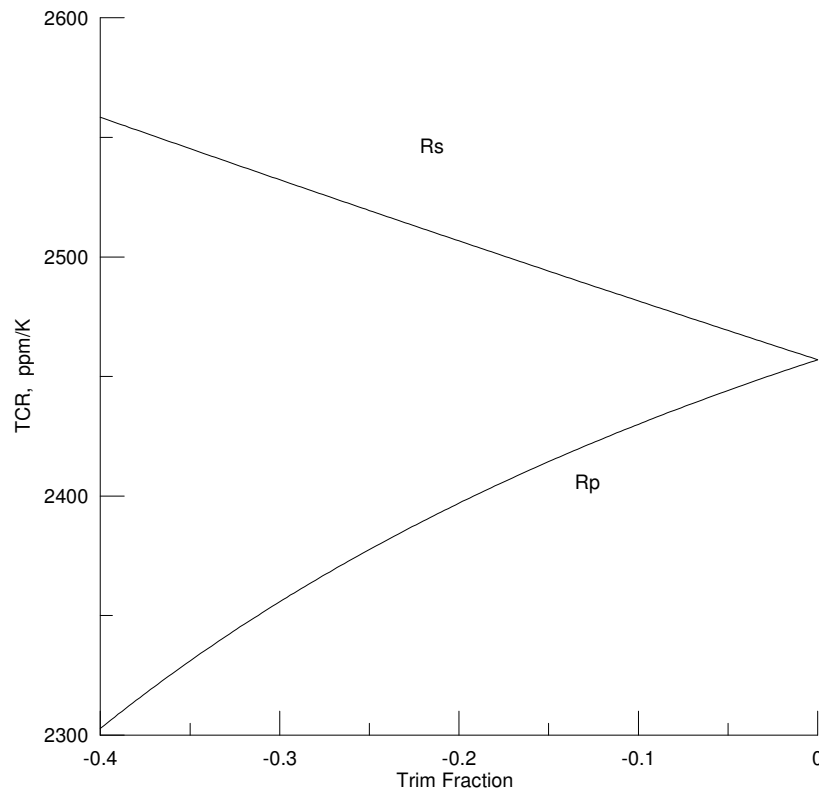

Figure 3: TCR Adjustment Profiles: “TCR” is the TCR of the overall resistance $R_{s+(R_p||R_b)}$. “Trim Fraction” is the trim fraction referred to the as-manufactured resistance value of the specific resistor R_p or R_s .

The curves in Figure 4 show how Offset and TC_Offset behave when each of the four **Rejustors** are adjusted. For example, adjusting Rs2 decreases the Offset of the system while increasing TC_Offset. When the sensor is mismatched, sequential adjustment of two **Rejustors** (correctly selected from the four) corrects Offset and TC_Offset to zero from any initial mismatch.

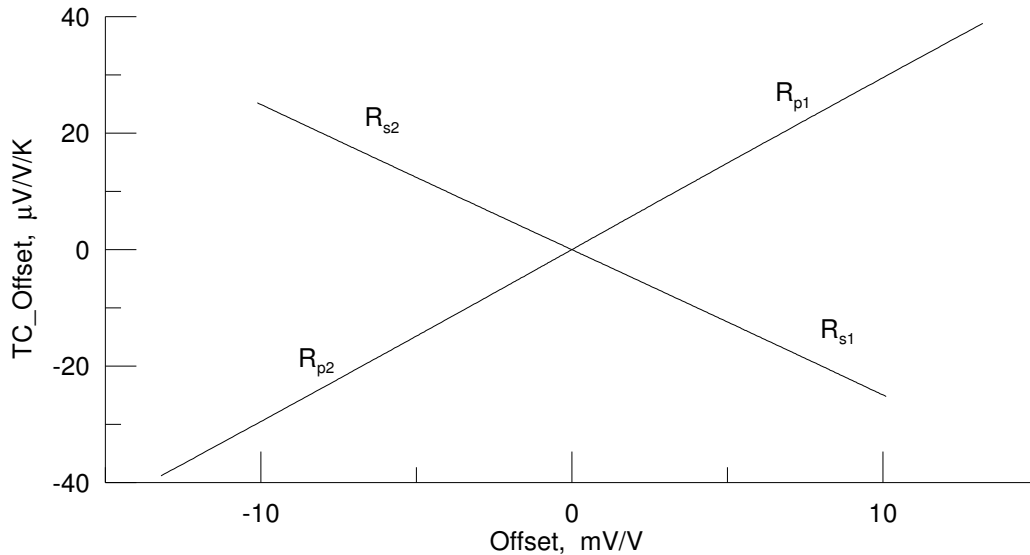

Figure 4: TC_Offset Adjustment

3.2 Sensitivity adjustment

Rejustors R1 and R2 (Figure 1) allow sensitivity compensation of pressure die. Attenuation adjustment in the range from 1.5 to 6.5 times, depending on the **Rejustor** configuration, allows tuning of sensitivity to the standard target $5\mu\text{V/V/mmHg}$ value, as typically required for compensated catheters.

3.3 TC_Sensitivity

The typical technical requirement for precision in catheter applications is about 3mmHg within the temperature range of 30C to 45C. The initial TC_Sensitivity of the SM5108 pressure die is about -1900ppm/K. Connecting two **Rejustors** R1 = 5K and R2 = 6K results in a positive temperature coefficient of voltage across the bridge (excitation voltage) of about +1000ppm/K. This compensates the negative TC_Sensitivity of the pressure die to improve the overall TC_Sensitivity to -900ppm/K. This translates to measurement error about $\pm 0.5\text{mmHg}$ at temperature variation of $\pm 5^\circ\text{C}$. Therefore, individual adjustment of the TC_Sensitivity is not needed.

4 MBN-2108 with SM5108

The schematic of the sensor and compensation circuit is shown in Figure 5, below. The signals Vex, GND, Vout- and Vout+ are provided at the connector interface. These signals are generated/received by the pressure monitoring equipment. A four-pin connector is adequate for this implementation. Signals V+, V-, S+, S- are connected to the sensor. The remaining signals (H1 through H6 and HGND) are **Rejustor** adjusting signals. These signals are only connected to the calibration fixture when the **Rejustors** are being adjusted.

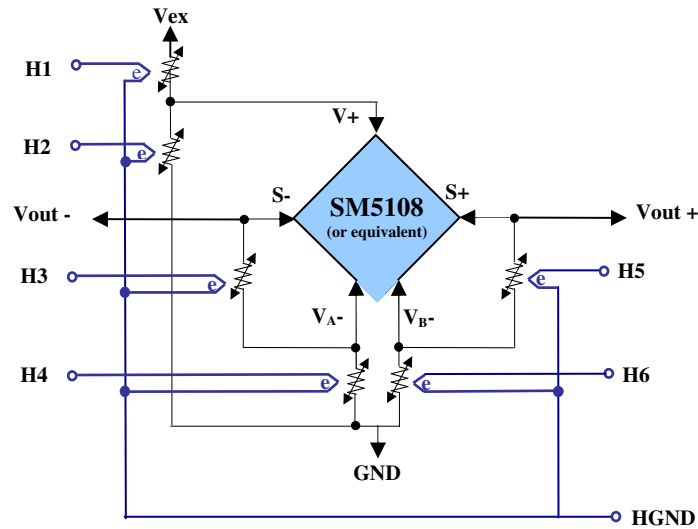

Figure 5: Schematic Representation

4.1 Sensor

The SM5108 sensor is attached in a split-bridge configuration on a substrate. The split-bridge configuration is recommended to improve noise immunity. The sensor (on the substrate) is connected at the end of the lumen¹. The lumen can be any length. The wires in the lumen tend to act as an electrical antenna. The split-bridge configuration opens the bottom of the bridge, as shown in Figure 1. Since both sides of the sensor are exposed to the same electrical noise, this noise can be cancelled with a traditional differential amplifier (in the catheter monitoring instrument).

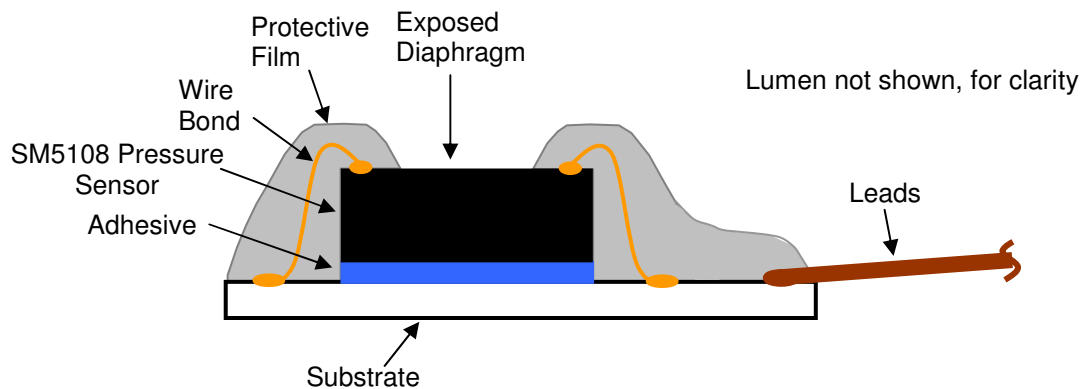

Figure 6: Catheter - Sensor Assembly

The mechanical configuration for the sensor portion of the catheter is shown in Figure 6. The sensor is mounted on a substrate with wire-bonds making the electrical connection between the sensor and the substrate. The assembly is covered with a hermetically sealed film or epoxy which protects the delicate wire-bonds and electrically seals the assembly. Note that the pressure sensitive membrane on the sensor must remain exposed. The leads at the other end of the lumen connect to the MBN-2108 assembly.

¹ Lumen - inner space, cavity or channel within a tubular structure. In this case, it refers to the plastic tubing containing the sensor and the wires which is partially inserted into a cavity.

4.2 MBW-5018 Assembly

The MBN-2108 Compensation **Rejistor Network** is designed to be installed in the connector housing of the sensor assembly. The MBN-2108 is manufactured in a 3mm square QFN, surface-mount package. A small PCB (printed circuit board) can be produced to mount the MBN-2108 and perform electrical connections. Refer to Figure 6. The board includes through-hole connections for both the sensor leads and the connector to the pressure monitoring equipment. The bottom-side of the board has pads to connect with the calibration fixture.

As described in Section 3, the compensation network does not need to be at the same temperature as the sensor in order to meet the performance requirements for pressure catheters with 5mmHg sensitivity. Installing the **Rejistor Network** in the connector is convenient because it doesn't increase the size of the inserted portion of the catheter. Furthermore, as a passive compensation device, no additional electrical signals are required from the pressure monitoring equipment, making catheters with MBN-2108 compensation easy to deploy in most applications.

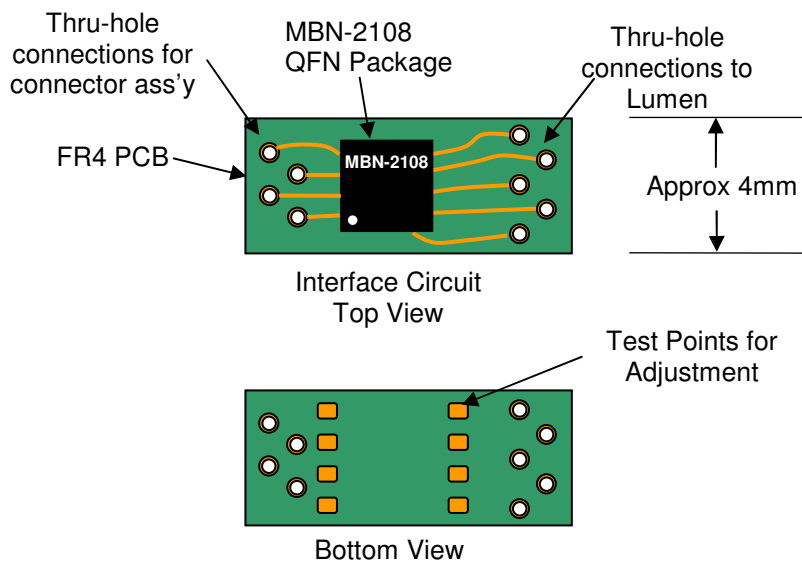

Figure 7: MBN-2108 Interconnect Assembly

The calibrated MBW5108 is assembled into the shell of the connector housing. A strain relief is required on the lumen to prevent the wires from being disconnected from the circuit board under moderate force. Refer to Figure 8. The connector and shell can be purchased from vendors such as Fischer Connector.

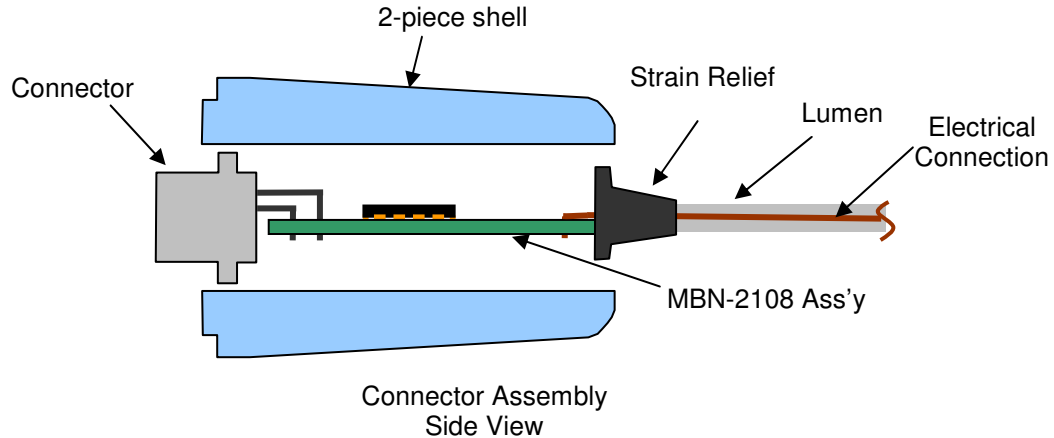

Figure 8: Connector Assembly with MBN-2108

4.3 Calibration Fixture

The catheter is assembled with the MBN-2108 soldered to the printed circuit board (PCB) shown in Figure 7. The five-wires from the sensor are soldered to the through-holes on the right. The connector need not be assembled until after the calibration is complete. In this way, these holes can be used as alignment guides for the calibration fixture.

The calibration process requires four data points representing ambient pressure and high pressure at low and high temperatures. **Rejutors** are adjusted using the adjust pins labeled H1 to H6 in Figure 5. These pins must be connected to the calibration fixture to adjust the **Rejutors** to meet the requirements of the sensor. **Rejutor** adjusting hardware can be configured from off-the-shelf ADC and DAC hardware from vendors such as National Instruments. Optionally, the **Rejutors** can be adjusted with the Microbridge Technologies MBK-408, a low cost adjustment tool for **Rejutor** applications. Consult with Microbridge Technologies for more information regarding adjusting hardware. The **Rejust-it** software can be integrated into the manufacturing flow to control the entire measurement and adjust process; including applying different temperature and pressure to the sensor.

Conventionally the circuit board is assembled as shown in Figure 8 with the sensor connected through a length of wire and the connector body mounted through rigid pins or short wires. Since the sensor is connected as a differential bridge the length of wire does not significantly degrade the signal. The assembly is pressed against a “bed-of-nails” test jig, Figure 9, which makes contacts with the signals available on the lands on the secondary side of the PCB. The response of the entire assembly is monitored through the connector for the four calibration points (described above). The **Rejutors** are automatically (under **Rejust-it** control) adjusted to the appropriate resistance to meet the 5uV/V/mmHg sensitivity requirement while also compensating Offset and TC_Offset.

After adjusting the **Rejutors**, the connector is installed and the connector body is assembled.

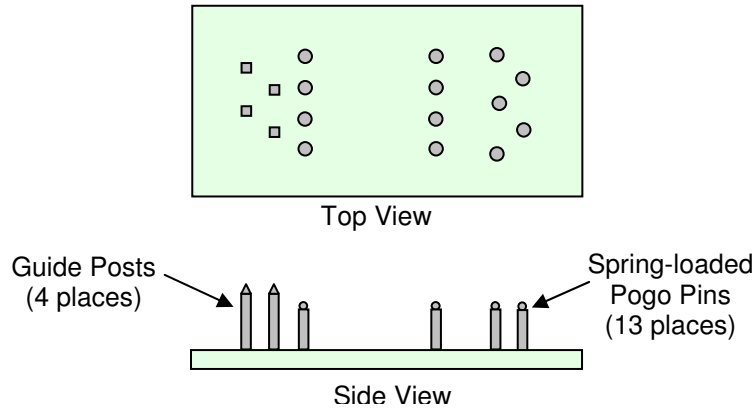

Figure 9: Calibration Fixture

4.4 Calibration Process

In order to calibrate the temperature coefficient of offset, the zero-load condition must be measured at two temperatures. Because it is not necessary to compensate the temperature coefficient of sensitivity, only a single high pressure measurement is required. Refer to Figure 10.

4.5 Sterilization

There are two principal methods to sterilize catheters; heat and radiation. The **Rejutor** compensation network has been analyzed based upon 30 minute sterilization procedure using heat at 200°C. The temperature can induce up to 4% drift in individual **Rejutors**, however the effects are balanced since catheter compensation is performed with a **Rejutor** network. Relative drift of the catheter can be considered in terms of:

- 1) **Offset:**
Rejutor drift results in 270uV/V output offset voltage increase, which translates to about 70mmHg.
- 2) **TC_Offset:**
Rejutor drift results in 0.6uV/V/K increase in TC_Offset, or about 1.8mmHg/K
- 3) **Span:**
Rejutor drift can result in sensitivity variation of approximately 0.6mmHg

The cumulative effect on Span (or sensitivity) and temperature-induced-zero-error are less than 3mmHg, combined. These fall below the minimum catheter sensitivity uncertainty threshold.

Offset drift is most noticeable in the final product. However, because it is standard practice to zero the catheter at the beginning of the procedure, the 70mmHg drift can be removed as a source of error during operation. Because the drift is always positive consider calibrating the offset to -50mmHg (for example) such that offset in the delivered product is closer to the zero specification.

Subsequent sterilization of the catheter assembly can cause the **Rejutor** drift to increase. **Rejutor** drift experiments performed by Microbridge show that individual **Rejutors** don't drift more than 1% after 2000hours (in fact, most of the 1% drift is observed within 400 hours after which the **Rejutors** no longer drift). From the analysis above, it can be deduced that subsequent sterilization of the catheter will cause the catheter drift to double. Again, because the majority of the drift is observed in offset and this is zeroed as part of the catheter operating procedure, this drift is not expected to negatively affect the catheter assembly.

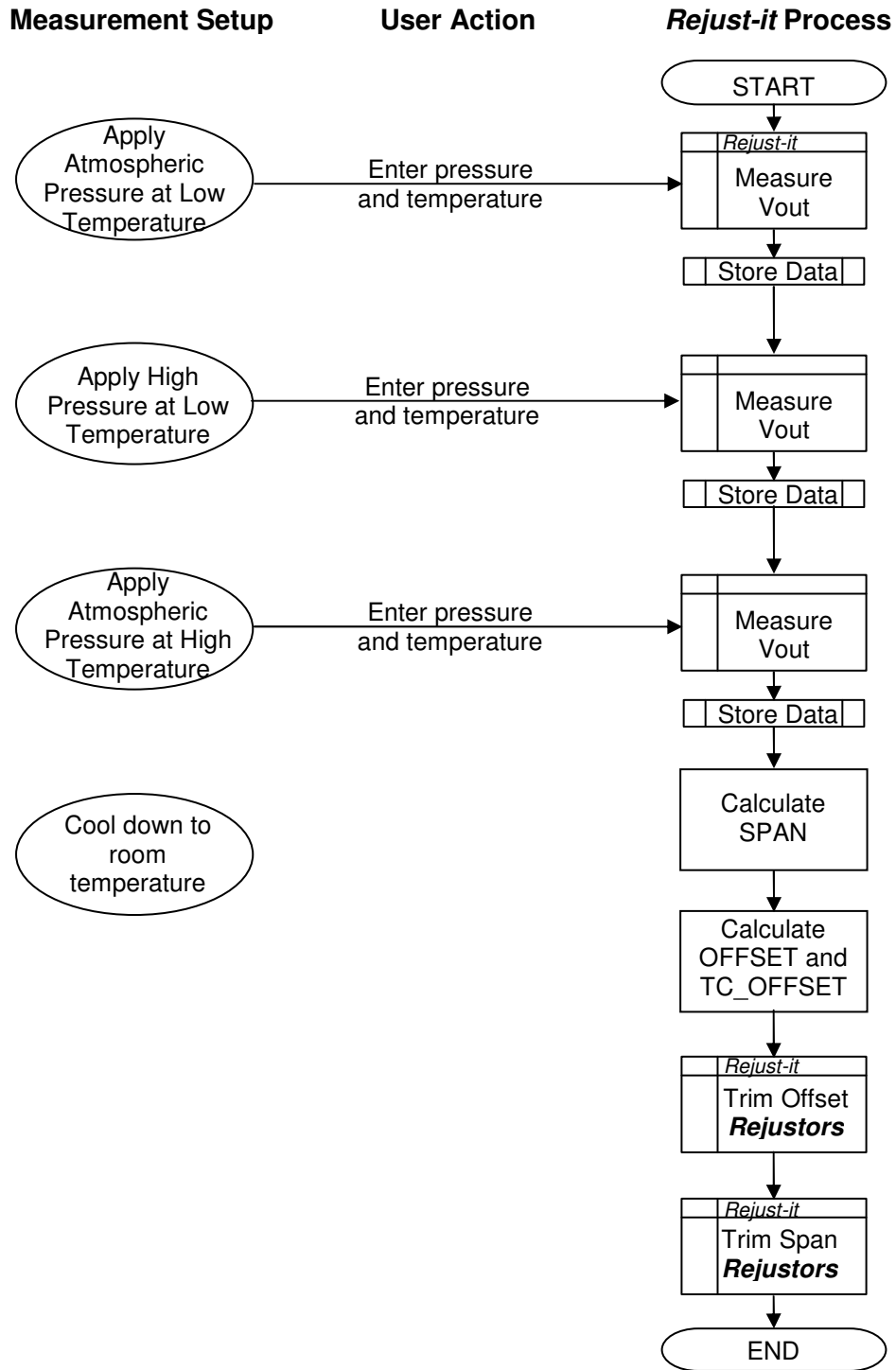

Figure 10: Calibration Flow Chart

5 Summary

This application note described an implementation using the MBN-2108 **Rejutor** Compensation Network with the SM5108 Pressure Sensor for Pressure Catheters. The **Rejutor** network is not connected in proximity to the sensor. This makes for the smallest possible catheter tip. Using a method referred to as Bridge Sensor Compensation/ Conditioning Using Non-local **Rejutor** Network, the MBN-2108 is installed in the connector and performs all compensation using only passive resistive elements.

The pressure sensor can be compensated using the configuration shown in Figure 1 to meet the sensitivity and accuracy requirements across expected temperature variations in both the sensor and the **Rejutor Network**. Offset can be adjusted with a precision of ± 0.3 mmHg by adjusting the resistances of Rs1, Rs2, Rp1 and Rp2. The temperature coefficient of offset (TC_Offset) is controlled by adjusting the TCR of the same **Rejutors**. TC_Offset can be controlled to a precision of < 0.1 mmHg/°C. Sensitivity is adjusted with R1 and R2 to achieve the $5\mu\text{V/V/mmHg}$.

Overall resistance of the compensated sensor is approximately $7\text{K}\Omega$. The unit can be used with an excitation voltage up to 5.5V. With the SM5108, the linear pressure range is ± 500 mmHg

Specification	Performance
Sensor	Piezo-resistive pressure sensor
Sensor size	Approx 2 French
Excitation	$5\text{V} \pm 10\%$ AC or DC
Resistance	Approx $7\text{K}\Omega$
Linear Pressure Range	0 to 500 mmHg
Sensitivity	$5\mu\text{V/V/mmHg}$
Compensated Temperature Range	30 to 45 °C
Temperature Coefficient of Zero	$< \pm 0.3$ mmHg
Temperature Coefficient of Sensitivity	$< \pm 0.3$ mmHg
Linearity	$< \pm 0.5\%$ FS
Connector	4-pin minimum (Lemo or equivalent)
Storage Temperature	-55 to +150 °C

The MBN-2108 **Rejutor** network compensated offset and temperature coefficient of offset, and span to meet the requirements of the catheter equipment vendors. Temperature coefficient of span on the SM5108 sensor is adequate to meet the requirements without additional compensation from the **Rejutor** network.

The sensor die is mounted at the tip of the catheter using a split-bridge configuration to improve noise immunity. The die is sealed with a protective film to prevent contamination and protect the delicate wire bonds. A leads within a lumen of any reasonable length connects the sensor to the connector.

The MBN-2108 is mounted on a printed circuit board within the connector housing. Exposed pads on the bottom of the PCB are used to adjust the **Rejutors** through the calibration test fixture. Each sensor and **Rejutor** combination must be monitored at three data-points. Low (approx 30°C) temperature measurements are collected for zero applied pressure and high-pressure (approx 500 mmHg). The sensor is then heated to high (approx 45°C) temperature at zero pressure for the

final data point. The **Rejustors** are adjusted after all measurements have been collected. Adjusting the **Rejustors** consumes approximately 20 seconds.

Calibration and temperature-compensation is successful with **Rejustors** placed in the plug/connector housing, which remains at room temperature (not co-located with the sensor in the catheter at body temperature). The **Rejustor** is passive and requires no special power to operate, uses the same voltage as the sensor and there is sufficient real-estate in the connector housing to accommodate the **Rejustor** network.

REVISION HISTORY:

- Beginning with: V00, July 8, 2007.
- Revision V01, May 19, 2011. The unit ID for Microbridge's compensation network MBW-5108 has been previously changed to MBN-2108. This White Paper is updated to be consistent with the changed product nomenclature. Microbridge's website name in the page header has also been updated. Also, a small number of typographical changes.